

# MIDLAND METROLOGY LTD

# MVicky-1000PC

## Touch Screen Micro Vickers Hardness Tester



# Features and Applications

The digital micro Vickers hardness tester is a high-tech product integrating optics, mechanics, and electronics. It features a high-definition touch screen for display and operation. With its novel, aesthetically pleasing design, it offers excellent intuitiveness, operability, and reliability. The machine employs an automatic switching device between the indenter and objective lens for automatic positioning, making it an ideal product for testing micro Vickers hardness.

## Product Features

- High-definition touch screen display and operation.
- Automatic switching device and positioning between indenter and objective lens.
- The instrument adopts precise mechanical design, is controlled by cpu for the testing process electrically, and utilizes a high-definition optical measurement system optically, enhancing the testing accuracy of the hardness tester.
- Micro vickers and knoop hardness options available.
- Selection of all microhardness scales.
- Conversion between various hardness scales.
- Pre-setting of test force dwell time.
- Adjustment of measurement light source intensity.
- After measuring the indentation diagonal length and pressing the input button, the hardness value is displayed on the screen, along with prompts for the number of hardness tests performed, etc.
- Built-in printer for printing hardness test results.

## Product Applications

- Hardness testing of various metal materials such as steel, aluminum alloys, copper alloys, etc. Enables users to understand the hardness properties of materials, thereby assessing their machinability and service performance. Applicable for hardness testing of non-metallic materials such as ceramics, glass, rubber, etc.



# Product Details

## Structure



- 1. Halogen Light Source   2. Eyepiece Interface   3. Eyepiece   4. Automatic Turret**  
**5. Indenter   6. X-Y Test Stage   7. X-Axis Handwheel   8. Elevating Lead Screw**  
**9. Touch Screen**

# Product Details

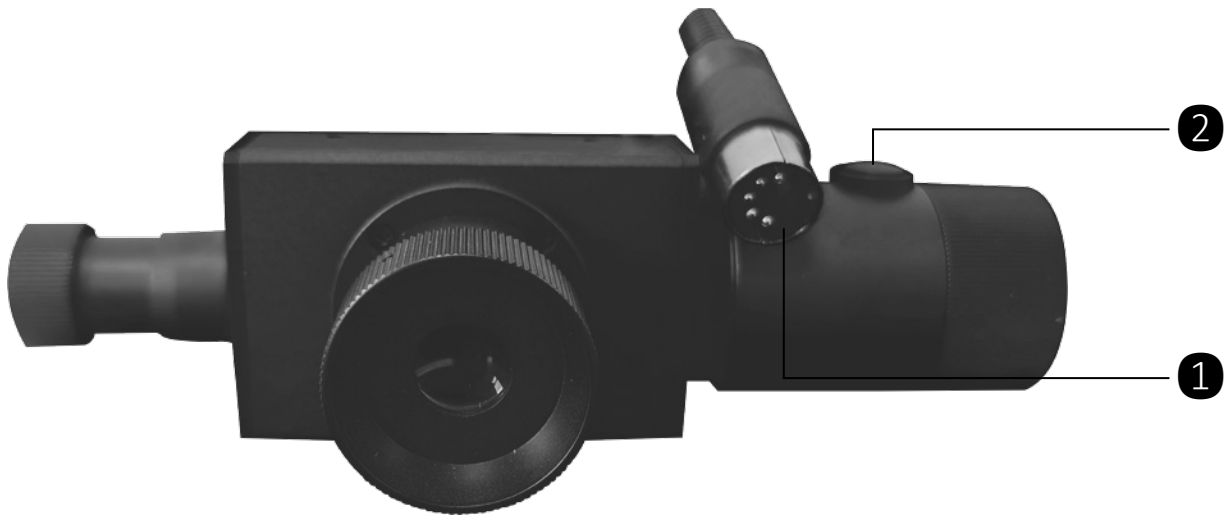

## 1. Eyepiece Interface

## 2. Input Button

After measuring the indentation diagonal length, press the input button to record the data. Both horizontal and vertical directions need to be recorded once.



Adjust the movement of the test stage in the X-axis direction via the X-axis handwheel. The elevating lead screw adopts a worm gear structure for more stable lifting.

# Product Details

## Structure



**1. Load Change Handwheel**

**2. Emergency Stop Switch**

**3. Handwheel**

# Product Details



- Adjust the height of the lead screw via the handwheel.
- Adjust the test force magnitude via the load change handwheel.
- Emergency stop switch



- Printer: Printed data includes maximum value, minimum value, average value, and time.

# Product Details

## Structure



**1.Power: AC220V/50~60Hz**

**2. External DB9 Interface**

**3. Power Switch**

# Operation Interface

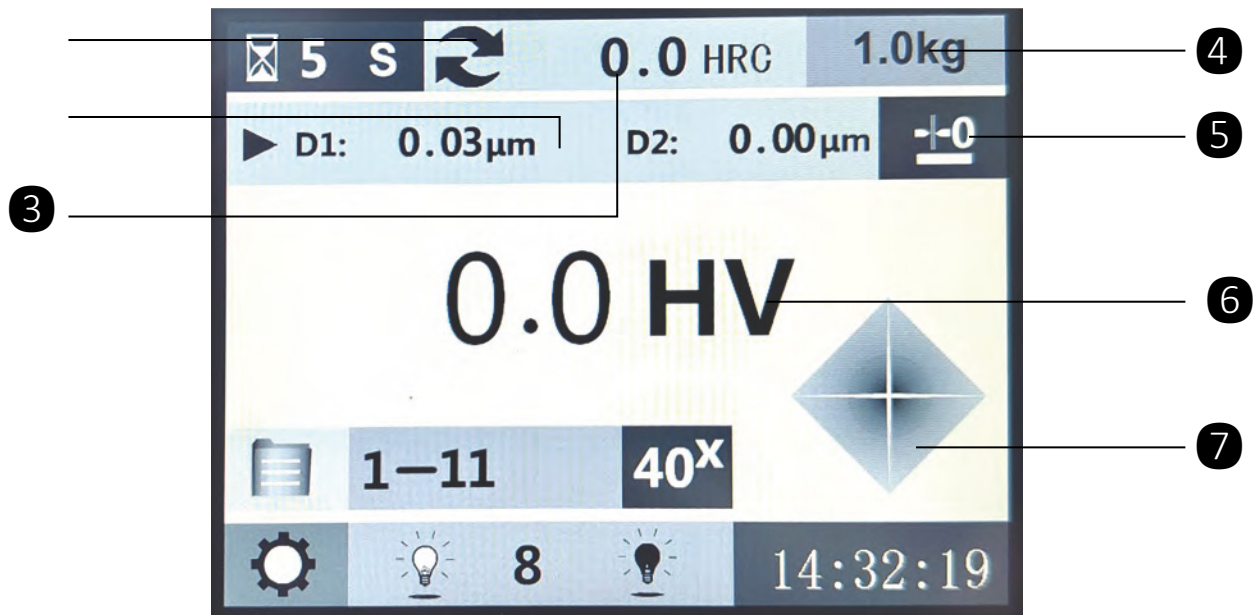

**1. Hardness Conversion**  
**4. Current Load**

**2. Measure Diameter**  
**5. Eyepiece Zeroing**

**3. Hardness Conversion Value**  
**6. Hardness Value**  
**7. Start**

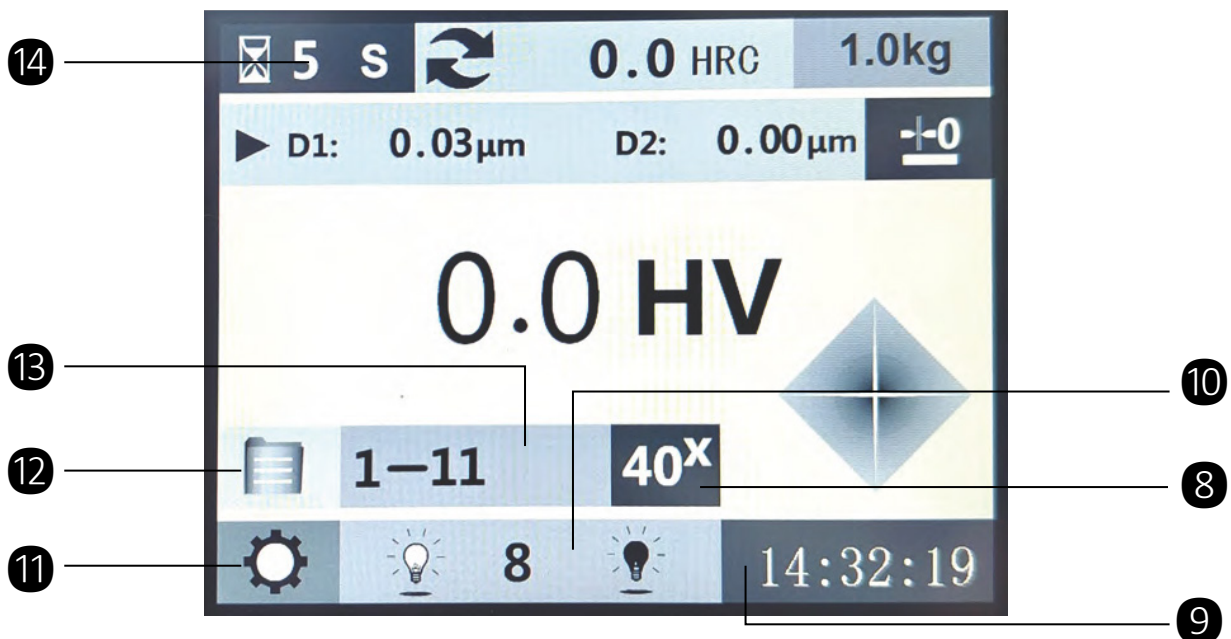

**8. Turret Conversion**  
**11. Settings**

**9. Time Display**

**10. Brightness Adjustment**

**12. Folder**

**13. Number Of Measurements**

**14. Dwell Time**

- Hardness conversion can be switched to Knoop hardness
- Load force dwell time 0~60s (in 5s increments).
- Zeroing operation is required before measurement to ensure accuracy of results.
- Turret selection: 10x objective, 40x objective, and indenter.

# Operation Interface

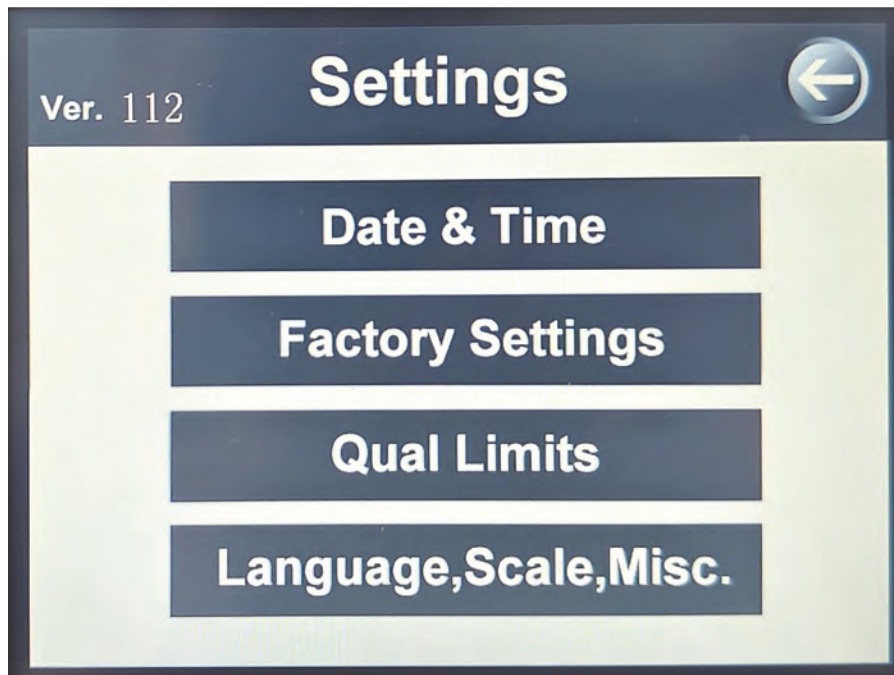

- Set time and date.
- Set language, scale, and other settings.

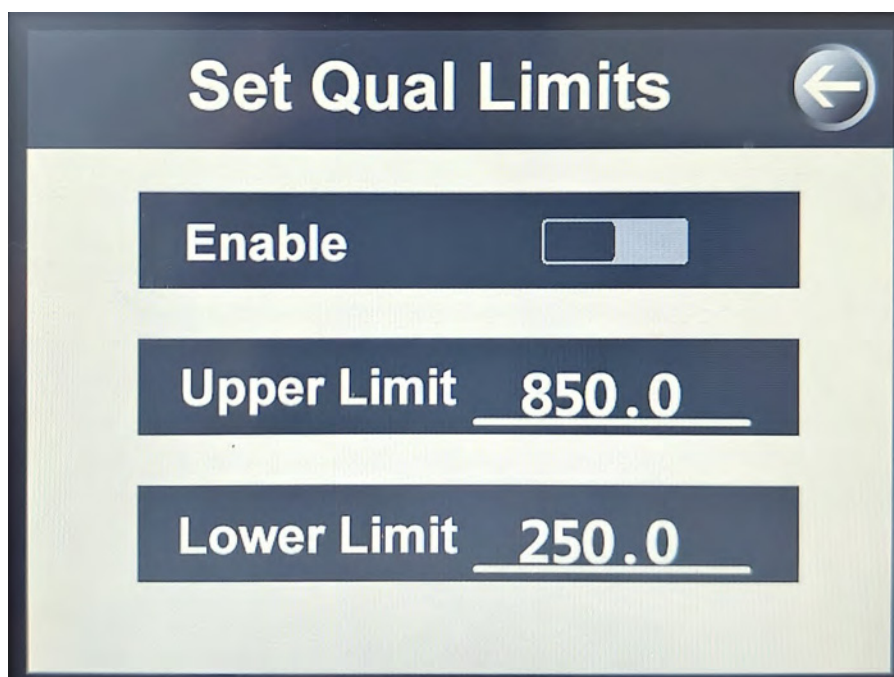

- Set upper and lower limits

# Operation Interface

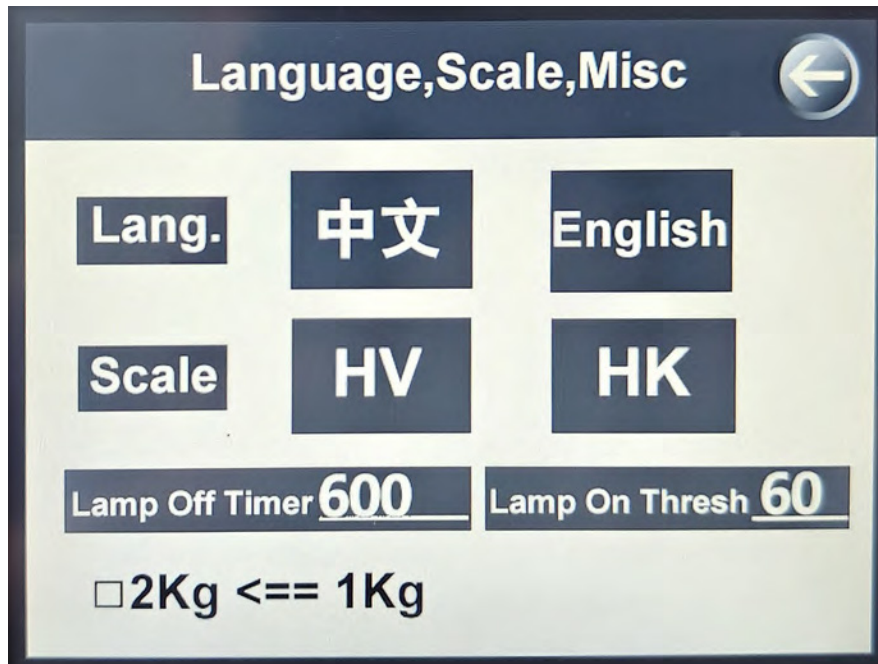

- Select the display language, Chinese and English are optional, and other languages can be customized 2 types of rulers to choose from, HV, HK.
- Set the time to turn off the light source and the light source brightness threshold.

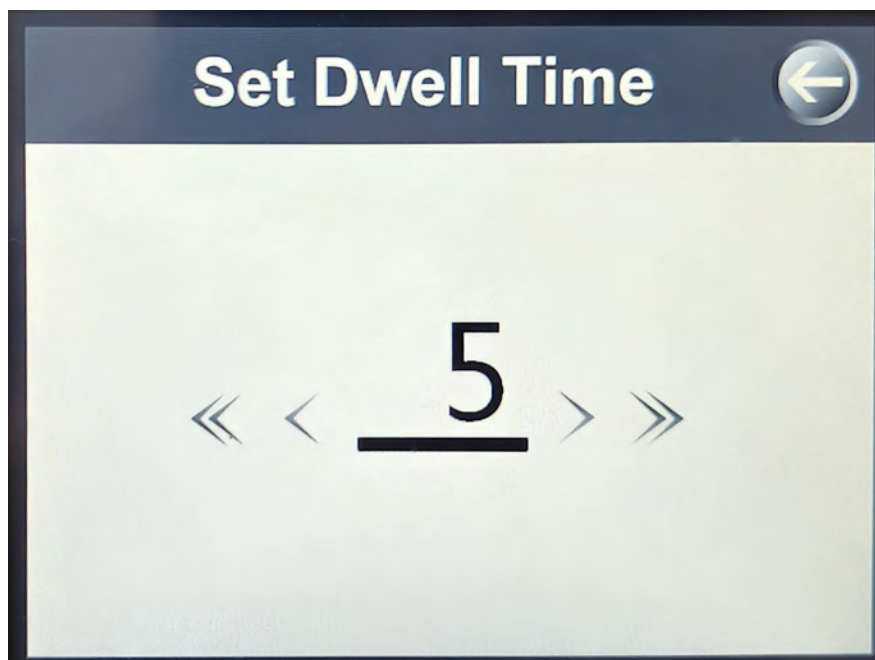

- Set the dwell time, with 5 seconds as a unit, ranging from 0 to 60 seconds, and the default is 5 seconds.

# Operation Interface



Data management: view, set, and clear data.

Select different folders to view data in the corresponding folder.

# Operation Interface

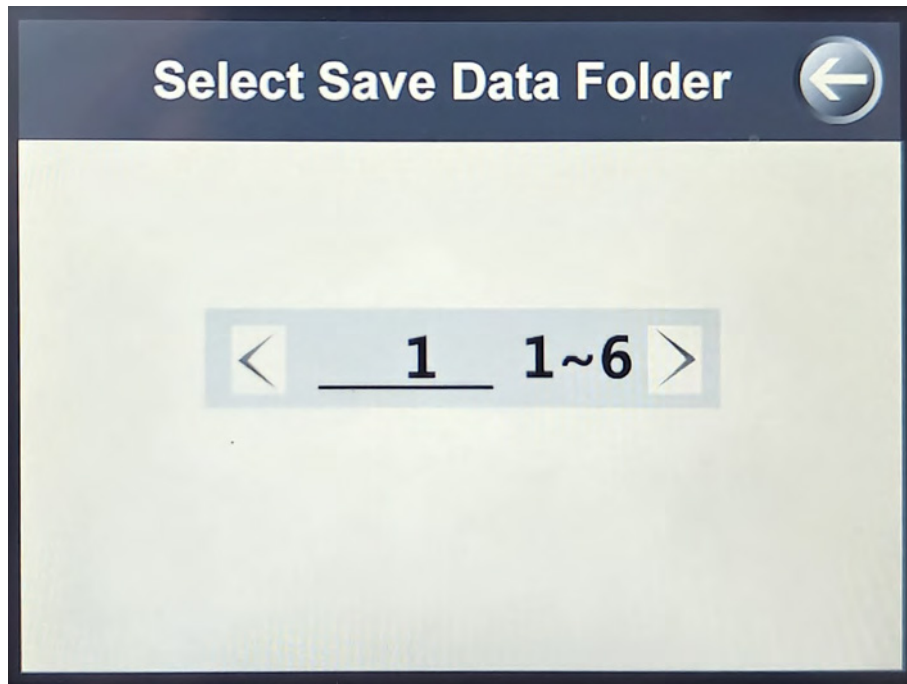

Select Folder to Save Data.

SEQ#	D1	D2	HV/K
✓1	49.34	49.37	761.2
✓2	48.71	48.71	781.5
✓3	47.59	47.59	818.7
✓4	49.09	49.12	769.0
✓5	49.37	49.37	760.8
✓6	49.78	49.78	748.3
✓7	49.65	49.65	752.2
✓8	49.62	49.62	753.1
✓9	49.68	49.68	751.3
✓10	49.59	49.59	754.0

HV 1.0kg  
FOLDER 1  
TOOL  
MAX 818.7  
MIN 748.3  
AVG 766.8

View recorded test data.

# Operation Interface

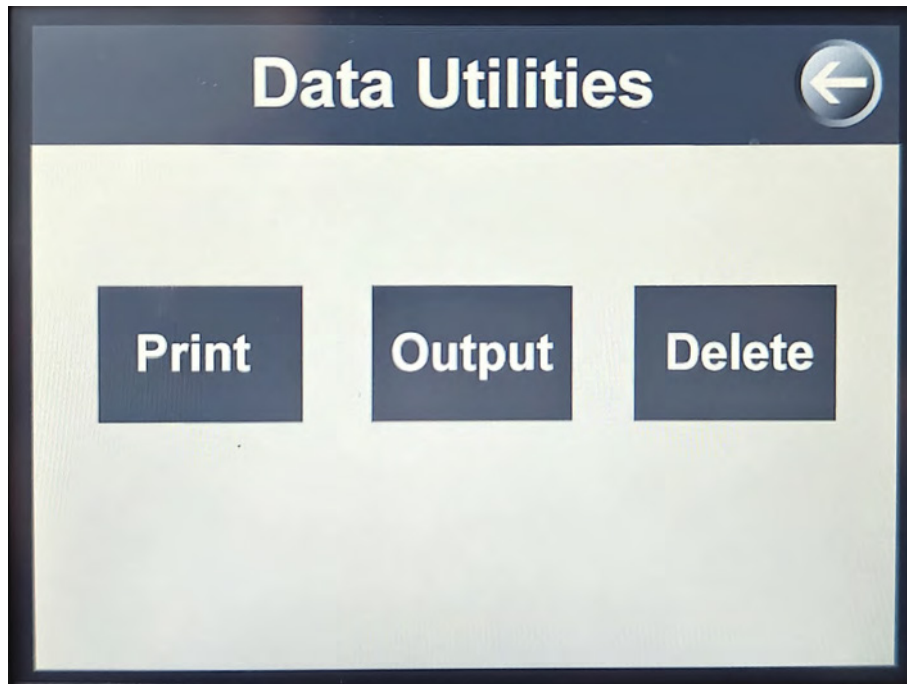

Process test data, including Print, Output, and Delete.

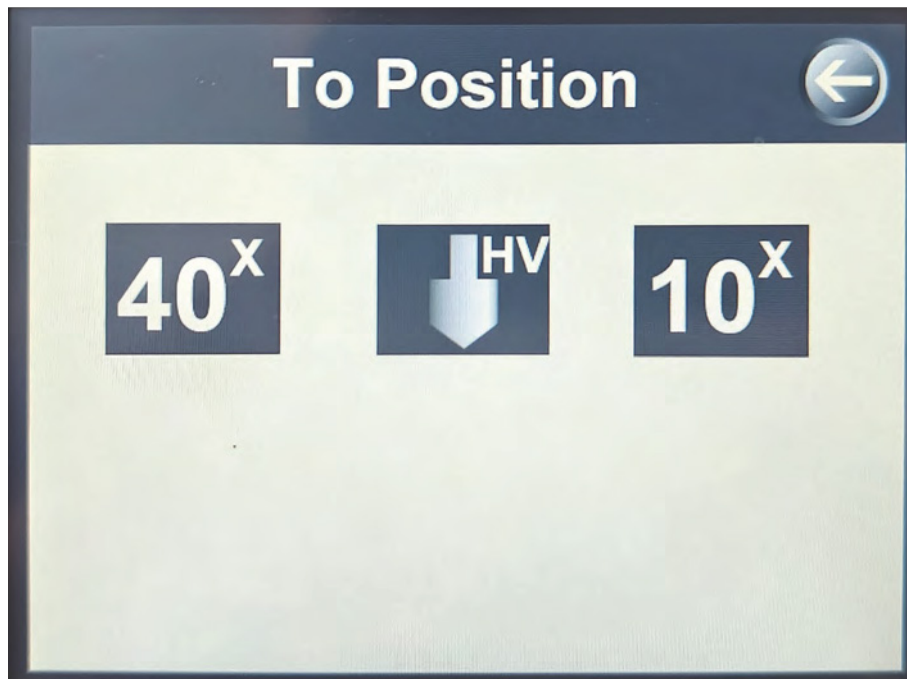

Selectable sequentially: 40x objective, indenter, 10x objective.

# Measurement Software

## Detail Display



**Adapter File**



**Industrial Camera**

- The adapter is used to connect the camera and the hardness tester, ensuring stable and reliable signal transmission between them. The adapter used in this device has good compatibility, sufficient stability and durability to ensure that the camera can work normally and capture clear images. Its user-friendly design facilitates users to install and remove the camera, as well as adjust the position and angle of the camera.
- Equipped with a 1.3-megapixel high-definition industrial camera, it is sturdy and durable in quality, with flexible parameter setting options such as exposure time, gain, white balance, etc. Users can finely adjust the camera according to actual application needs to obtain the best imaging effect.

# Measurement Software

## Software Interface

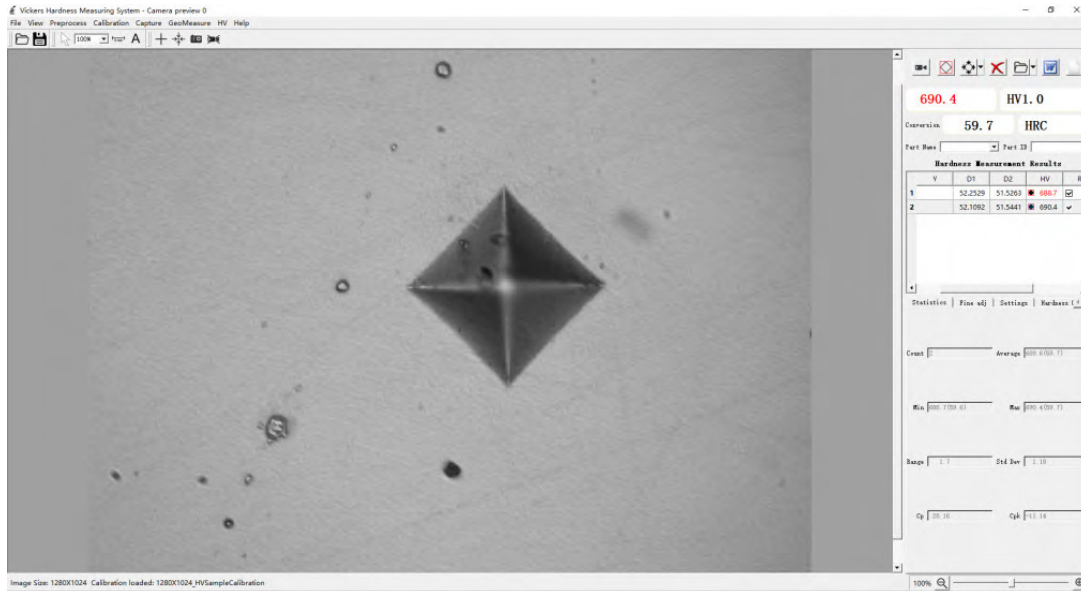

Main Interface

- This software is applicable to almost all hardness testers with camera ports. The system mainly provides the following hardness measurement functions:
- Automatic measurement
- Data statistics
- Data saving and retrieval
- Report output

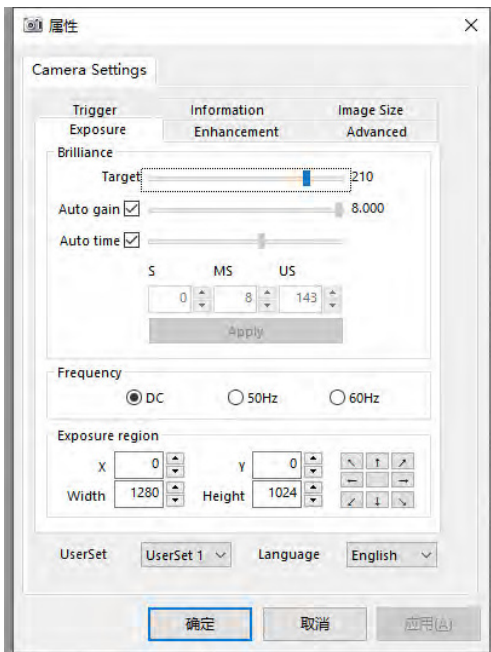

- When the indentation image is not clear and bright enough, users can adjust parameters such as image brightness, exposure time, and gain in this interface to improve the quality of the indentation image on the screen.

# Measurement Software

## Grid Display

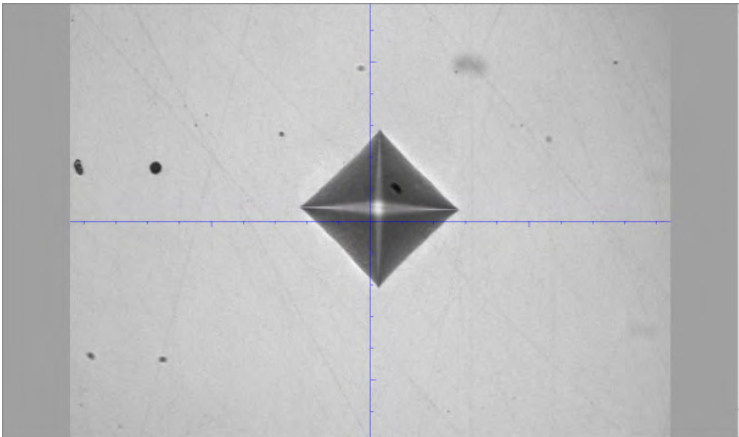

Crosshair Scale

- Sometimes, it is necessary to display a grid on the image as a reference.
- There is a button to show/hide the grid above the toolbar. The center of the grid can be changed freely by the user, which is convenient for users who need it.

## Hardness Measurement

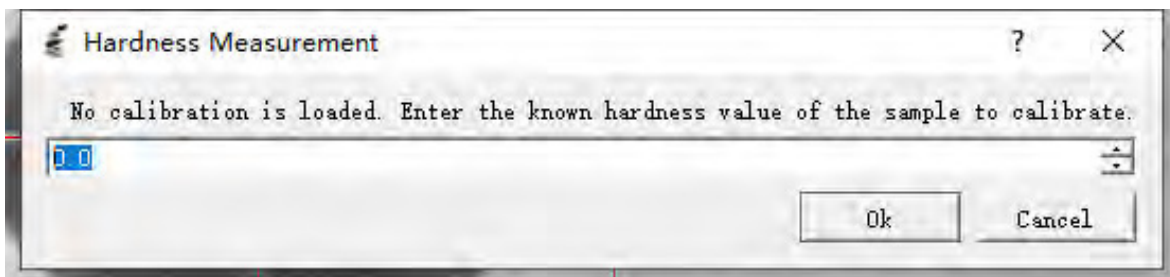

Calibration

- When using it for the first time to measure hardness, users need to perform calibration by themselves using a hardness calibration block, and the system will automatically save this calibration.
- If automatic measurement calibration is used, the system will automatically find and measure the indentation.
- If manual measurement calibration is used, after the mouse shape becomes a red cross, click the 4 fixed points of the indentation (the order is not limited).
- After measurement, the system will mark the indentation with a rectangle. If the rectangle mark is not accurately aligned with the indentation, the user can click with the mouse to make the mark accurately align with the indentation.
- Finally, enter the indentation hardness value, the calibration is completed, and the system will automatically save and load the calibration just performed.

# Measurement Software

## Calibration Viewer

- In this interface, users can manage the saved calibrations, including renaming, un-loading/loading calibrations.

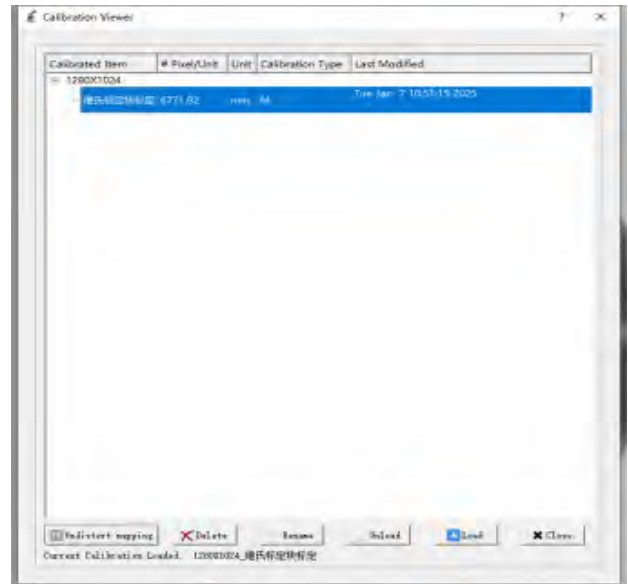

## Measurement Settings

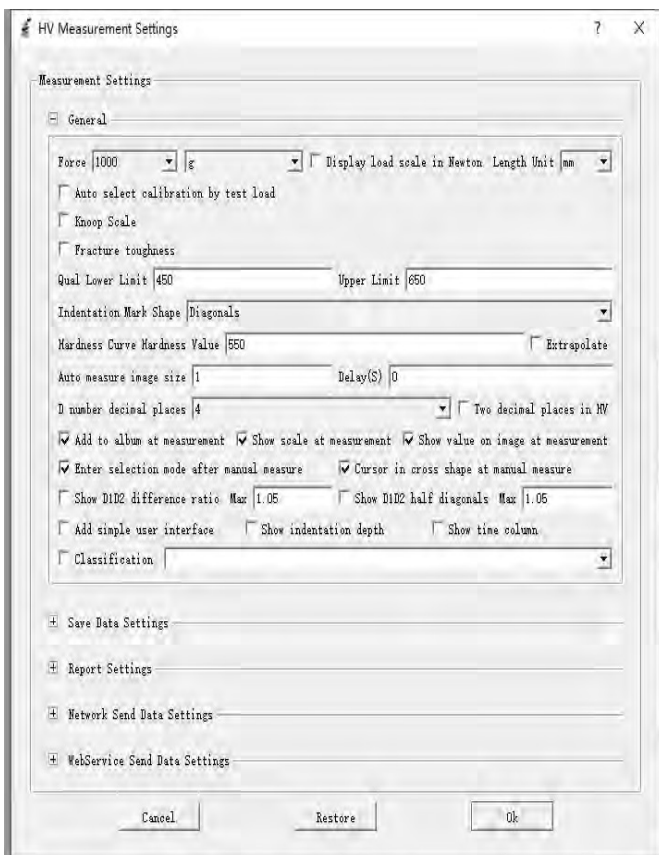

- Select the test force corresponding to the hardness tester, which is selected manually.

Select the test force unit, with g and kg available.

Auto-select calibration according to test force: after checking, users can first select the test force, and then perform corresponding calibration.

Select Knoop hardness: after checking, the measurement scale of this program will be changed to Knoop hardness.

Set alarm upper and lower limits, and measurement results beyond the range will be displayed in red font.

Indentation mark shape: rectangle, arbitrary quadrilateral, or diagonal can be selected to indicate the indentation measurement result. Rectangle is commonly used.

# Measurement Software

## Save Data Settings

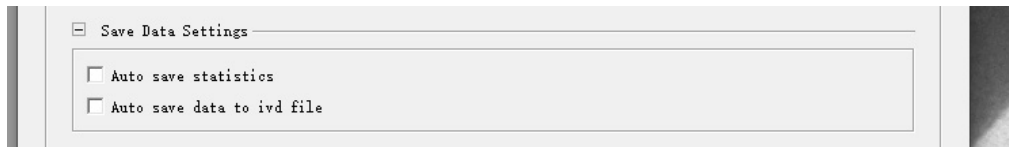

- Auto-save statistics: after checking, the measurement statistics will be automatically saved in the set folder.  
Auto-save data: after checking, the measurement data, including indentation images, etc., will be automatically saved in the set folder.

## Report Settings

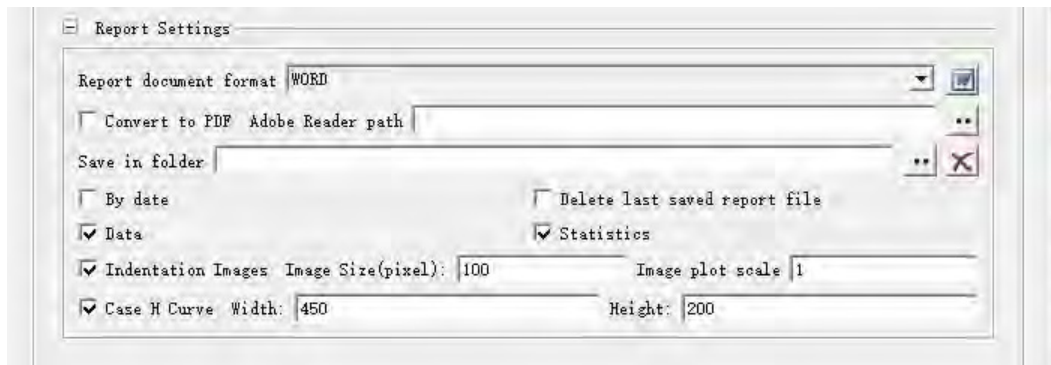

- There are 2 report document formats available, WORD or EXCEL can be selected.

## Common Buttons

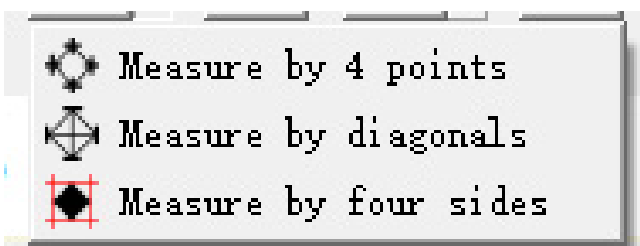
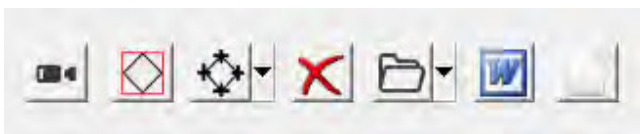

### Manual Calibration

- From left to right:
- Camera mode: after clicking, the real-time camera image will appear on the screen.
- Automatic measurement: after obtaining a clear indentation, click to allow the system to automatically find the indentation and calculate the hardness value, while updating the statistical data and indentation album.
- Manual measurement: the system provides 3 manual measurement methods: 4-point measurement; diagonal measurement; two-point and four-line clamping
- ~~Delete button~~: select the data and click this button to delete it.
- Data saving: click to save the test data.
- Report generation: click to generate a report, and the format can be modified in the report settings.

# Measurement Software

## Result Statistics

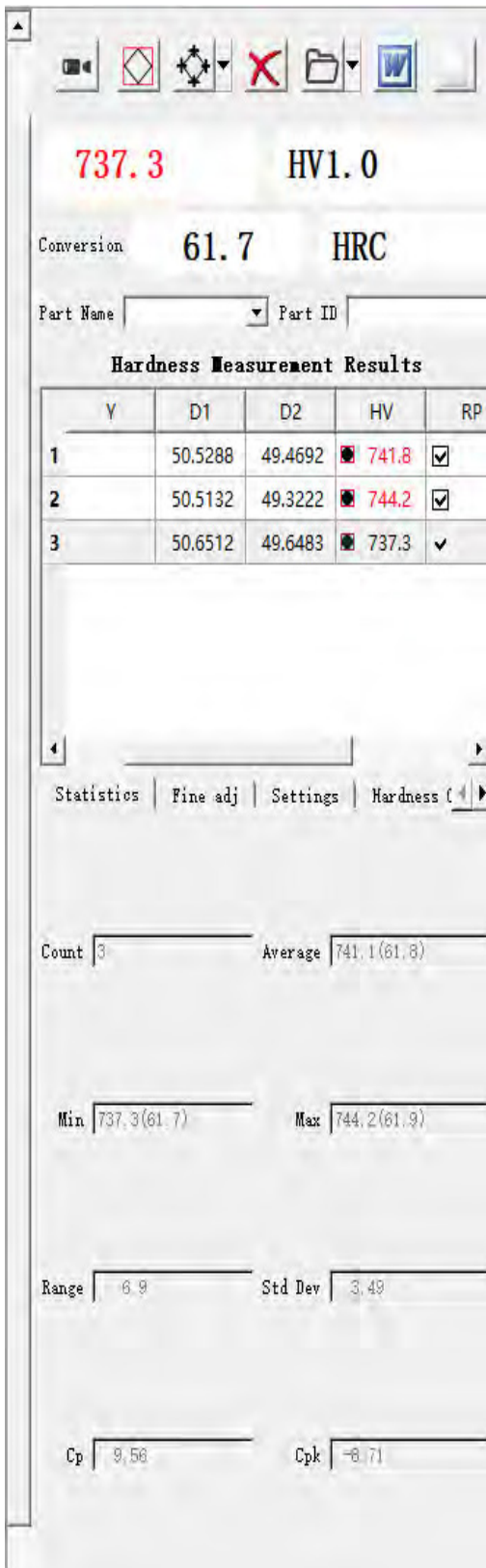

- After each measurement, the test results will be automatically counted and updated in the statistical column below. The data with unselected RP will not be included in the statistics and report.

## Hardening Curve

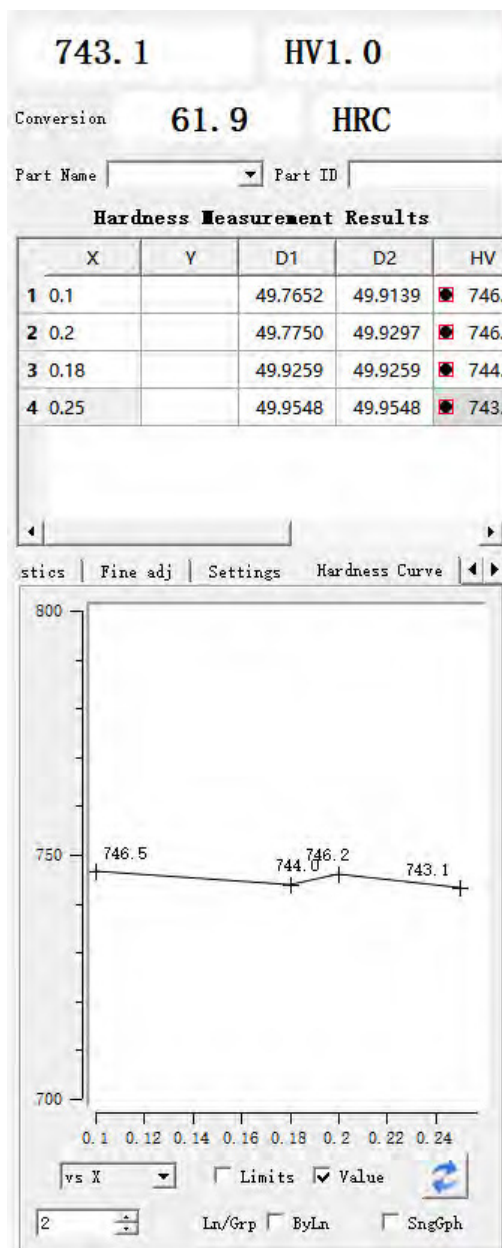

It is necessary to calculate the depth of the hardened layer, first manually input the sample depth of the test point into column X, then select "vsX" below, and the system will automatically generate multiple hardening curves.

# Measurement Software

## Hardness Conversion

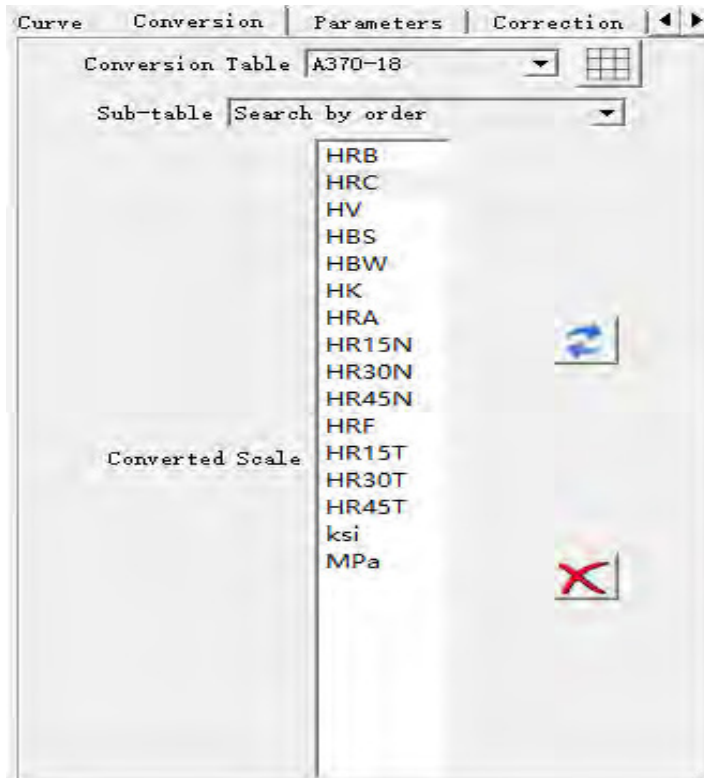

- When it is necessary to convert the measured HV hardness scale to other hardness scales, users can select the hardness scale to be converted in this interface.

## Correction

- For non-planar sample surfaces, the software will calculate the hardness correction value according to the correction table and the sample ball (cylinder) diameter entered in the settings. First, enter the sample ball (cylinder) diameter (mm), then select the sample surface type, and the hardness measurement result table will add a correction column.
- If "Show in Report" is checked, the hardness value displayed in the result table and report will be the corrected value instead of the original value.

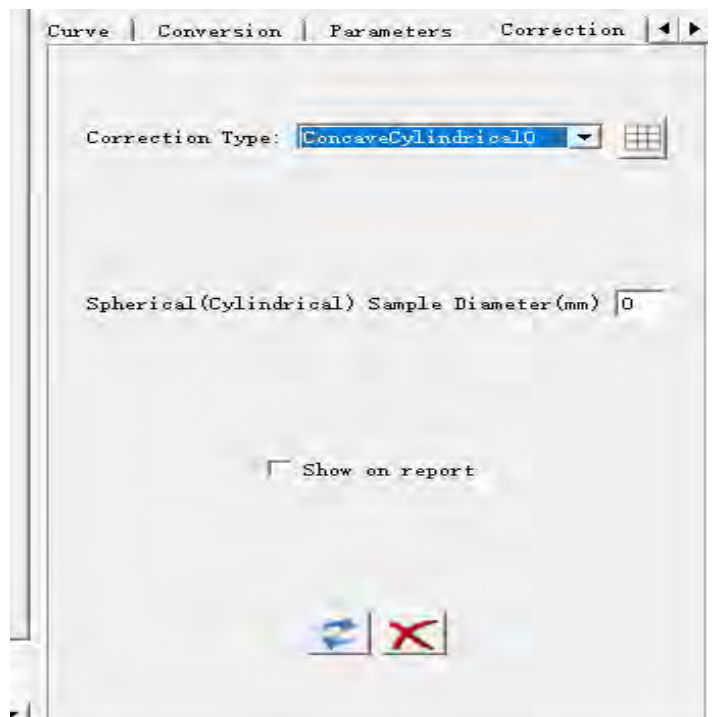

Surface Correction

# Measurement Software

## Album

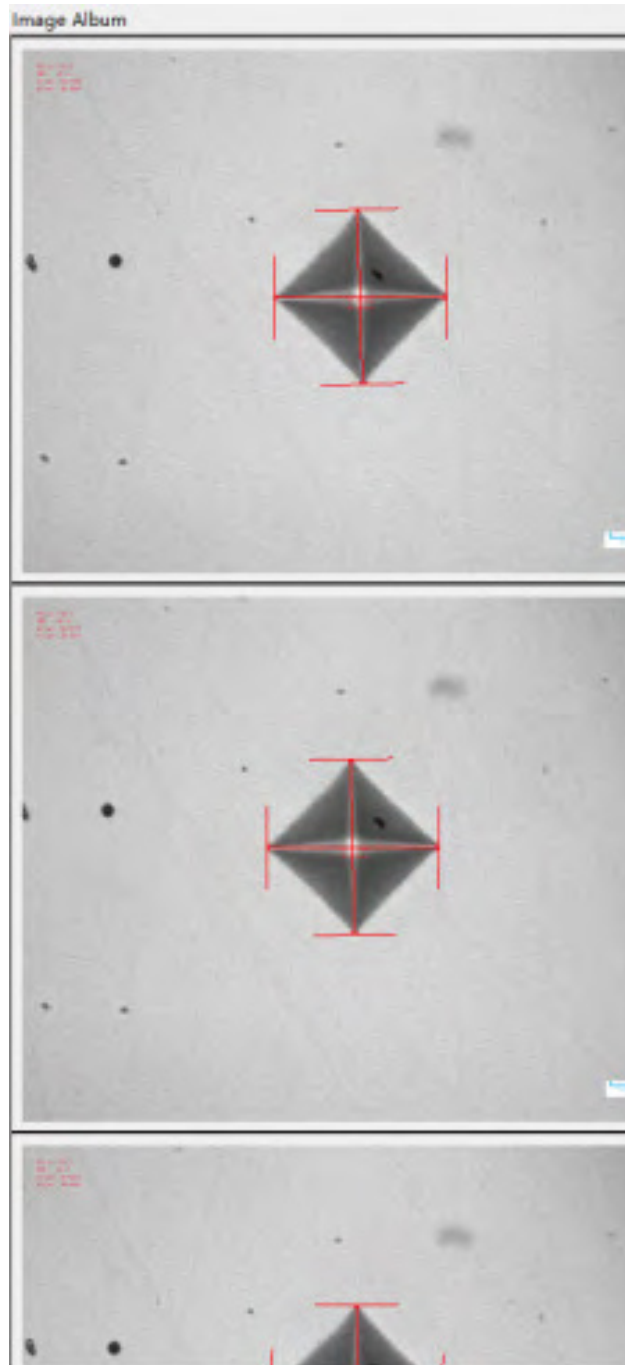

- The indentation images after measurement will be saved in the album. Clicking on the indentation image will display the corresponding hardness value and other information. The window position of the album can be adjusted freely by the user, and it is on the far right of the screen by default.

# Measurement Software

## Test Results

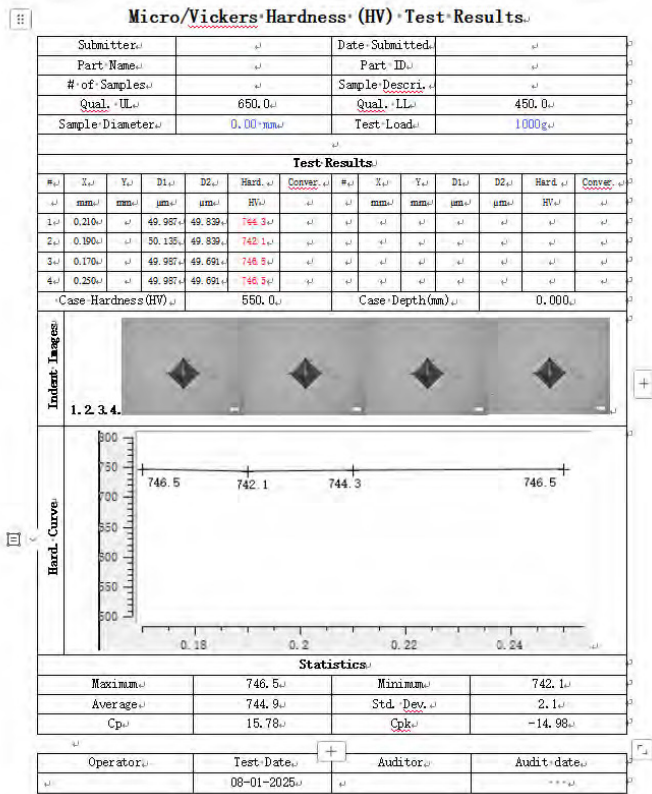

Word Format

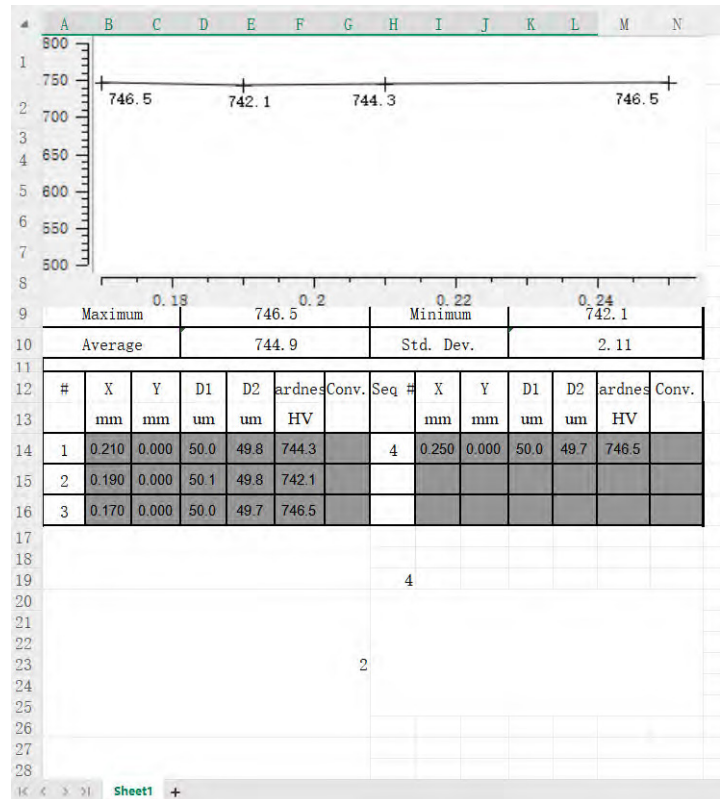

Excel Format

- According to the user's settings, the system will automatically generate a report in Word or Excel format. The report content includes test parameters, and can be set to include measurement data, indentation images, hardening curves, etc.

## Select Language

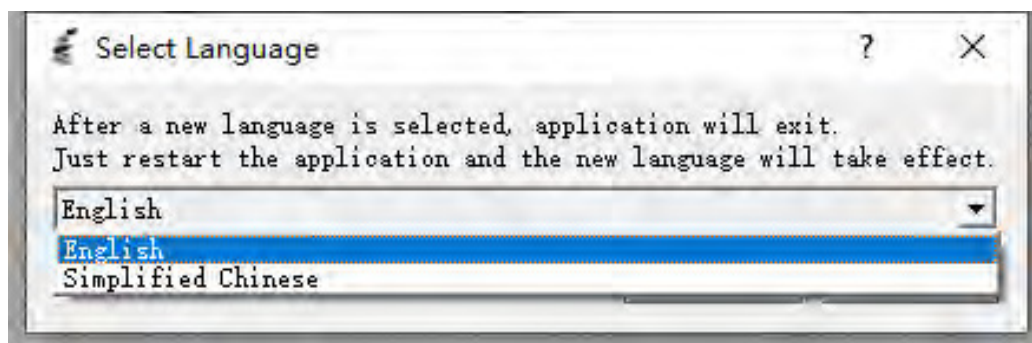

- This software currently supports two languages: English and Simplified Chinese, and supports customization of other languages.



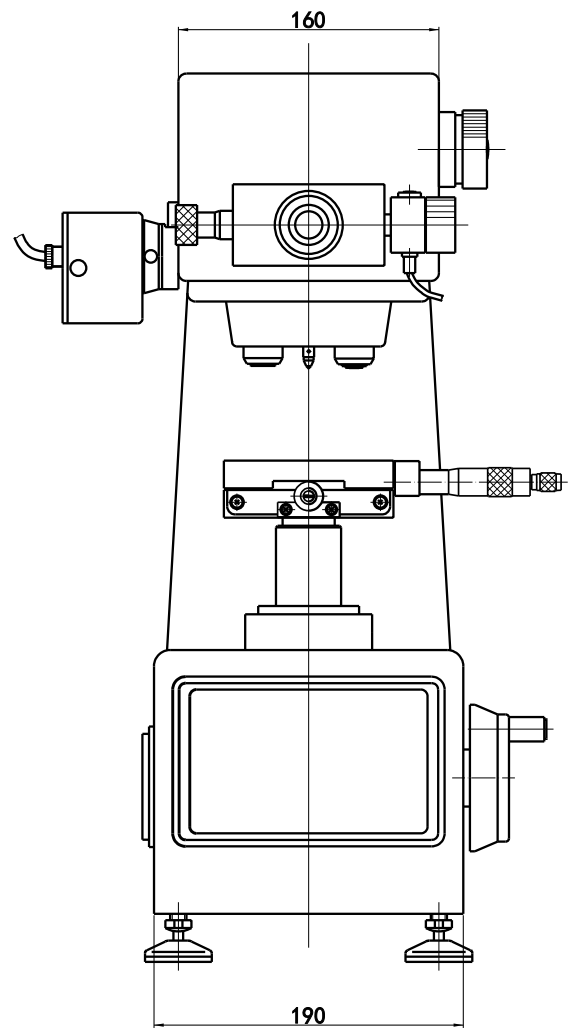
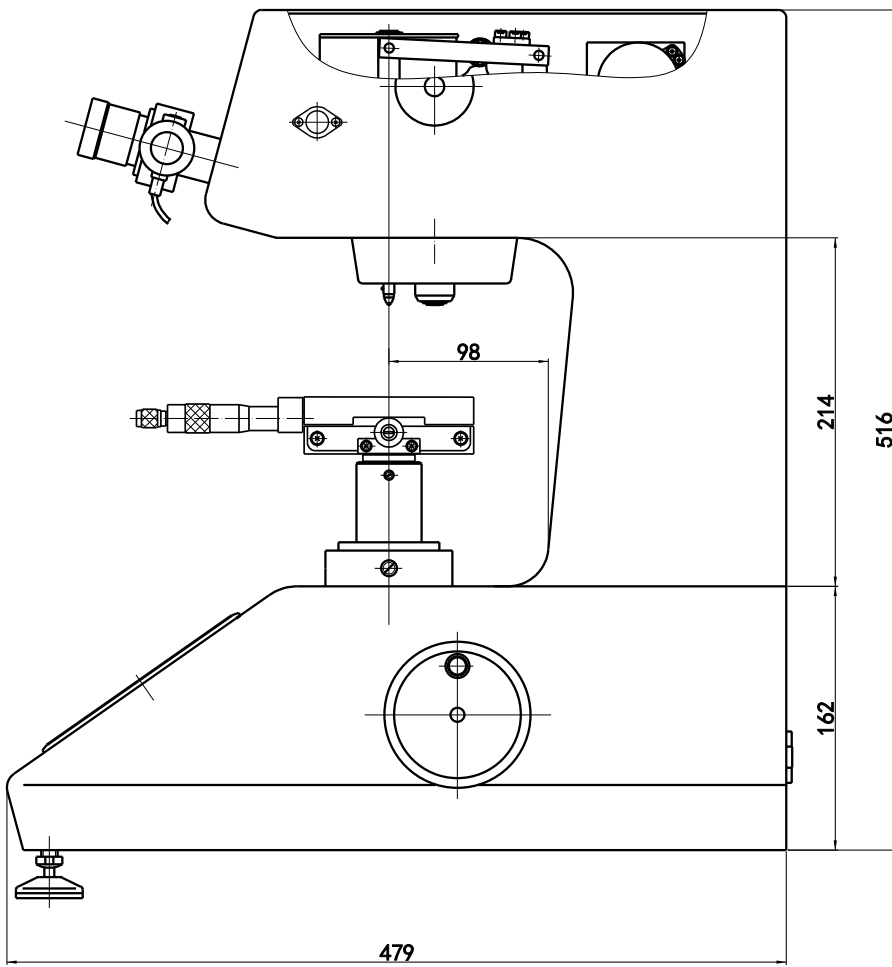



# Product Dimensions





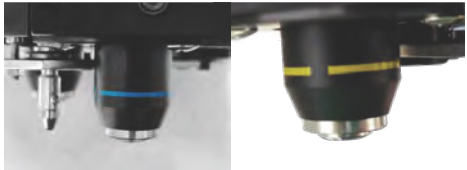

# Technical Specification

<b>Name</b>	Touch Screen Micro Vickers Hardness Tester
<b>Model</b>	MVicky-1000T 0.098N、0.245N、0.49N、0.9807N、1.961N、2.942N、4.903N、9.807N
<b>Test Force</b>	10gf、25gf、50gf、100gf、200gf、300gf、500gf、1kgf
<b>Indenter</b>	Diamond Indenter
<b>Test Force Application Method</b>	Automatic application and removal of test force
<b>Indenter And Objective Lens</b>	Automatic switching
<b>Test Force Dwell Time</b>	0~60s (in 5s increments)
<b>Eyepiece</b>	10X
<b>Objective Lens</b>	10X 40X
<b>Total Magnification</b>	100X 400X
<b>Resolution</b>	0.06μm
<b>X-Y Test Stage</b>	Size:100x100 mm
	Travel:25x25mm
	Resolution:0.01mm
<b>Maximum Sample Height</b>	90mm
<b>Indenter Center To Outer Wall</b>	100mm Within room temperature range
<b>Working Conditions</b>	(23±5)°C
	Placed horizontally on a stable base In a vibration-free environment, free from corrosive media Indoor relative humidity not exceeding 65%
<b>Power Supply</b>	AC220 V/50~60 Hz
<b>Net Weight</b>	31KG
<b>Dimensions (L X W X H)</b>	480x325x545mm

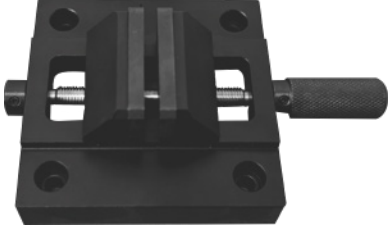

# Standard Delivery

Name	Specification	Qty	Photo
<b>Machine Mainframe</b>		1	
<b>Micro Indenter</b>		1	
<b>Objective Lens</b>	10X、 40X	each1	
<b>Measuring Eyepiece</b>	10X	1	
<b>Weights</b>		6	
<b>Weight Shaft</b>		1	
<b>X-Y Test Stage</b>		1	

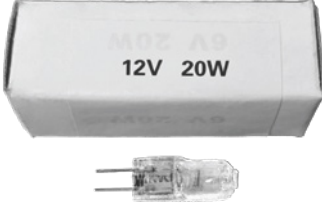
# Standard Delivery

Name	Specification	Qty	Photo
Flat Clamping Stage		1	
Thin Specimen Clamping Stage		1	
Fine Wire Clamping Stage		1	
Leveling Screws		4	
Spirit Level		1	
Halogen Lamp	12V、 15~20W	1	

# Standard Delivery

Name	Specification	Qty	Photo
Measuring Eyepiece	1A/250V 5X20mm	3	
Power Cord		1	
Screwdriver		1	
Hex Key		2	
Dust Cover		1	
Microhardness Blocks	HV0.2、HV1	each1	
Hardness Tester User Manual		1	
Certificate Qualification		1	
Product Qualification Certificate		1	
Accessories Box		1	

# Optional Delivery

## Optional Accessories

Knoop indenter

---

CCD image processing system

---

Vickers measurement software

---

Low-value HV1 Vickers standard hardness block (around 200)

---

Medium-value HV1 Vickers standard hardness block (around 500)

---

High-value HV1 Vickers standard hardness block (around 700)  
(Standard hardness blocks for other Vickers scales are optional)

---