

MIDLAND METROLOGY LTD

MVicky-1000T

Touch Screen Micro Vickers Hardness Tester



Features and Applications

The digital micro Vickers hardness tester is a high-tech product integrating optics, mechanics, and electronics. It features a high-definition touch screen for display and operation. With its novel, aesthetically pleasing design, it offers excellent intuitiveness, operability, and reliability. The machine employs an automatic switching device between the indenter and objective lens for automatic positioning, making it an ideal product for testing micro Vickers hardness.

Product Features

- High-definition touch screen display and operation.
- Automatic switching device and positioning between indenter and objective lens.
- The instrument adopts precise mechanical design, is controlled by cpu for the testing process electrically, and utilizes a high-definition optical measurement system optically, enhancing the testing accuracy of the hardness tester
- Micro vickers and knoop hardness options available.
- Selection of all microhardness scales
- Conversion between various hardness scales.
- Pre-setting of test force dwell time.
- Adjustment of measurement light source intensity.
- After measuring the indentation diagonal length and pressing the input button, the hardness value is displayed on the screen, along with prompts for the number of hardness tests performed, etc.
- Built-in printer for printing hardness test results

Product Application

- Hardness testing of various metal materials such as steel, aluminum alloys, copper alloys, etc
- Enables users to understand the hardness properties of materials, thereby assessing their machinability and service performance.
- Applicable for hardness testing of non-metallic materials such as ceramics, glass, rubber, etc.



Product Details



- 1. Halogen light source
- 2. Eyepiece interface
- 3. Eyepiece
- 4. Automatic turret
- 5. Indenter
- 6. X-Y test stage
- 7. X-axis handwheel
- 8. Elevating lead screw
- 9. Touch screen

Product Details

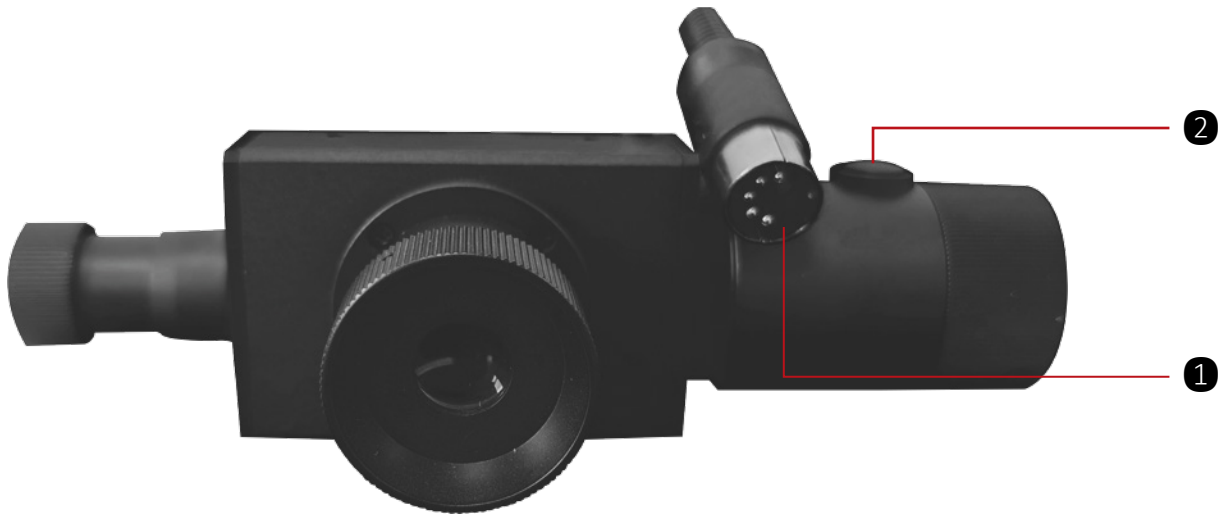

1. Eyepiece interface

2. Input button

After measuring the indentation diagonal length, press the input button to record the data. Both horizontal and vertical directions need to be recorded once.



Adjust the movement of the test stage in the X-axis direction via the X-axis handwheel. The elevating lead screw adopts a worm gear structure for more stable lifting.

Product Details



1. Load change handwheel

2. Emergency stop switch

3. Handwheel

Product Details



Adjust the height of the lead screw via the handwheel.
Adjust the test force magnitude via the load change handwheel.
Emergency stop switch



Printer: Printed data includes maximum value, minimum value, average value, and time.



1. Power : AC220V/50~60Hz

2. External DB9 interface

3. Power switch

Operation Interface

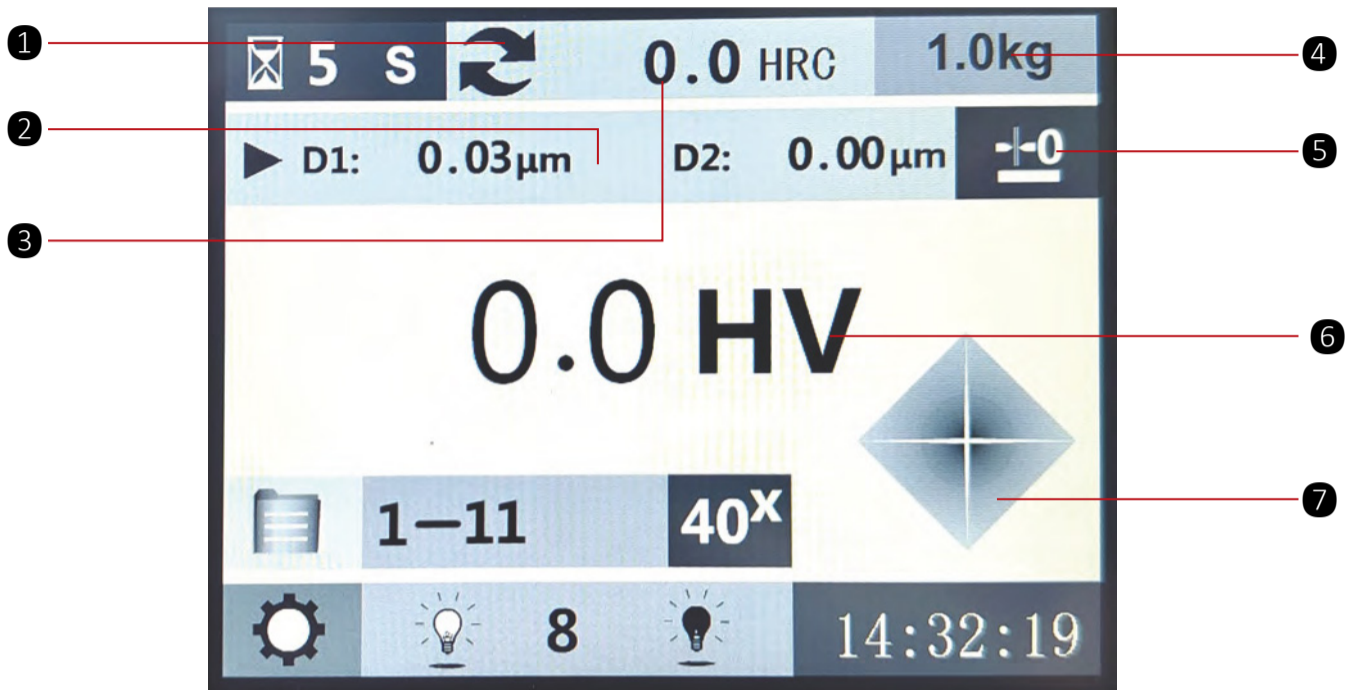

- | | | |
|-------------------------------|----------------------------|--|
| 1. Hardness conversion | 2. Measure diameter | 3. Hardness conversion value |
| 4. Current load | 5. Eyepiece zeroing | 6. Hardness value 7. Start |

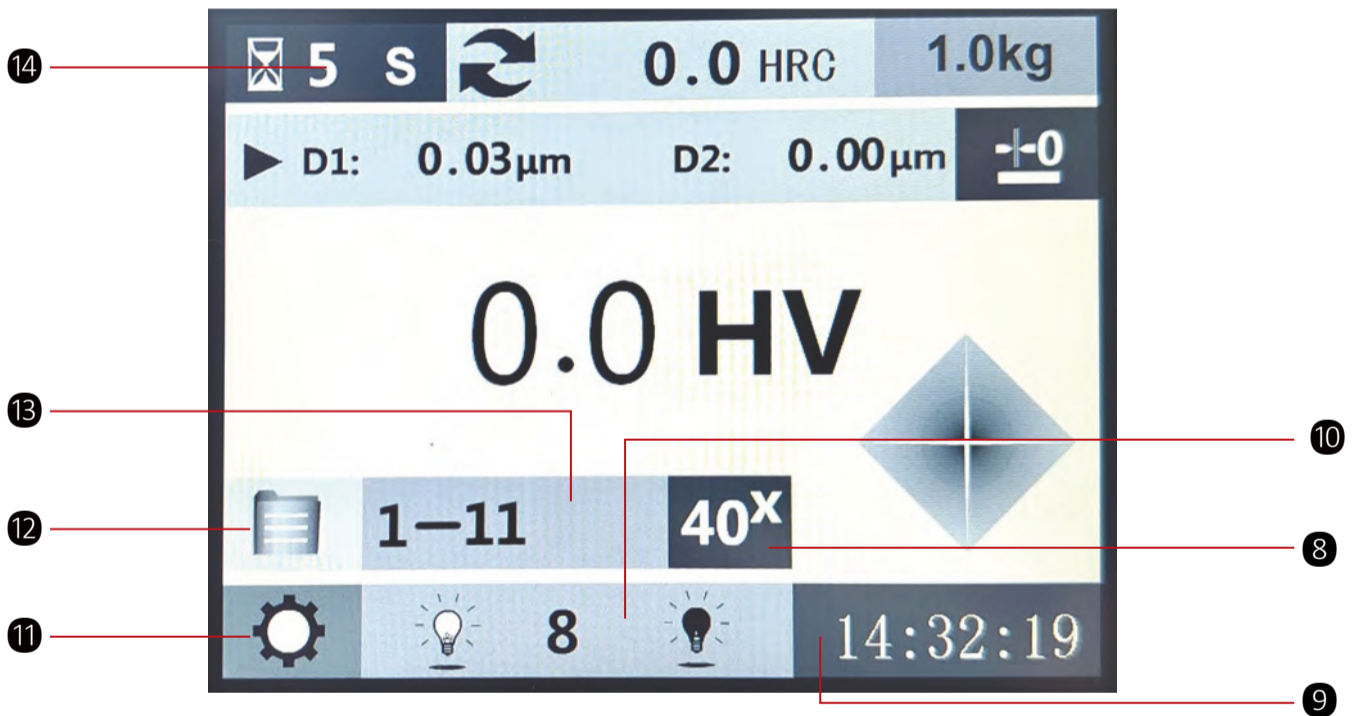

- | | | |
|-----------------------------|------------------------|---|
| 8. Turret conversion | 9. Time display | 10. Brightness adjustment |
| 11. Settings | 12. Folder | 13. Number of measurements 14. Dwell time |

- Hardness conversion can be switched to Knoop hardness
- Load force dwell time 0~60s (in 5s increments).
- Zeroing operation is required before measurement to ensure accuracy of results.
- Turret selection: 10x objective, 40x objective, and indenter.

Operation Interface

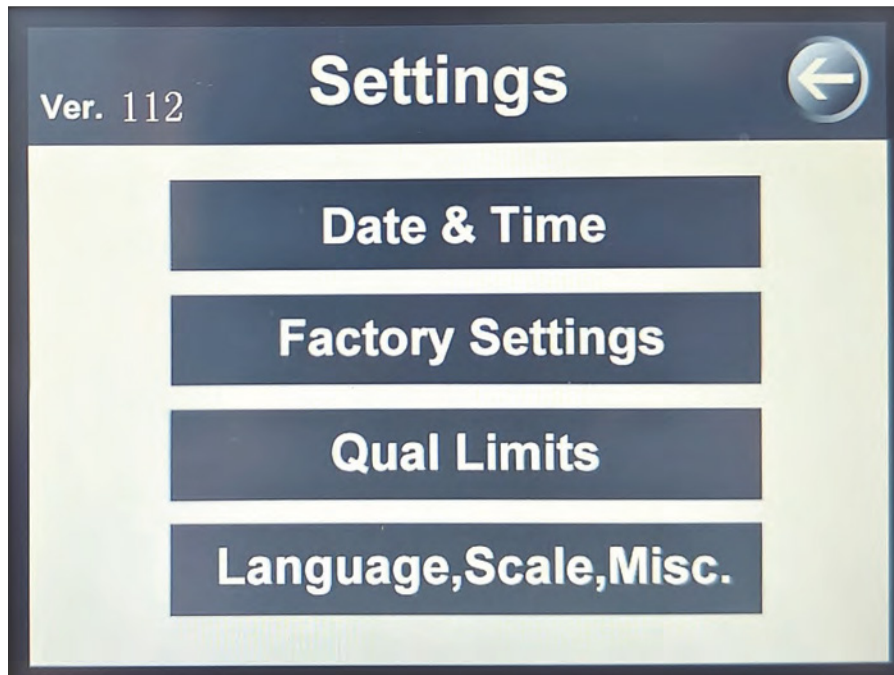

Set time and date.
Set language, scale, and other settings.

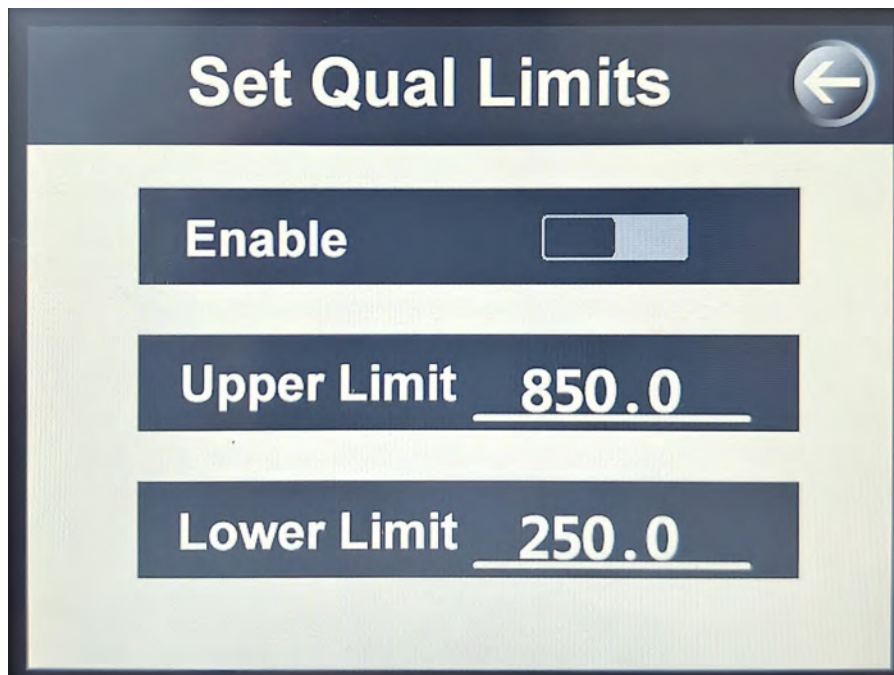

Set upper and lower limits

Operation Interface

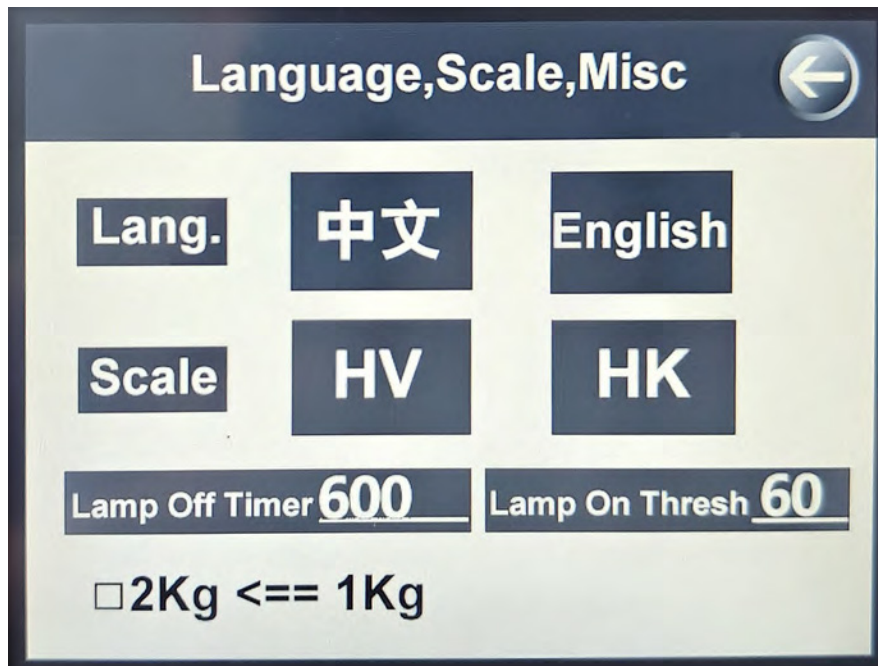

Select the display language, Chinese and English are optional, and other languages can be customized
2 types of rulers to choose from, HV, HK
Set the time to turn off the light source and the light source brightness threshold

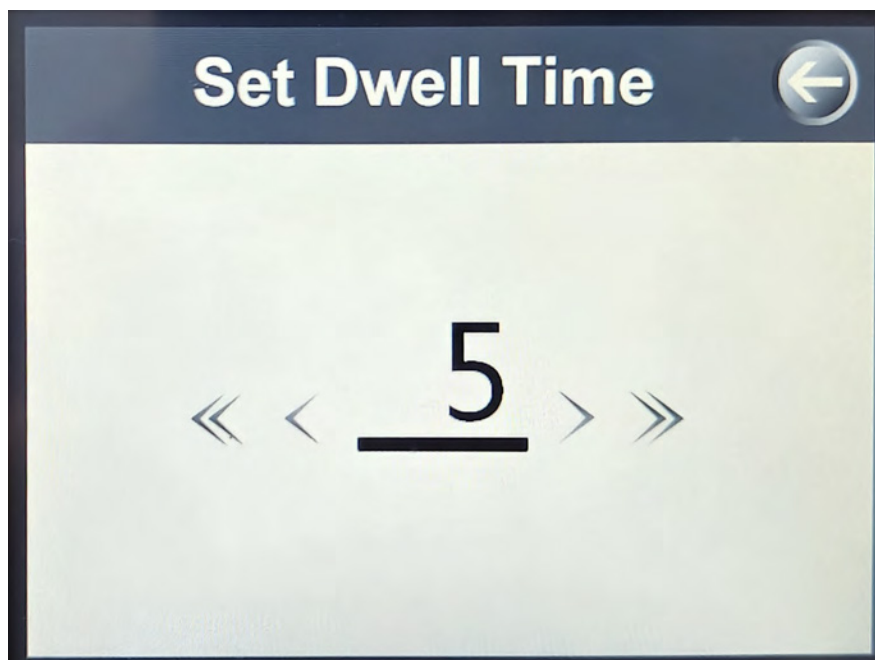

Set the dwell time, with 5 seconds as a unit, ranging from 0 to 60 seconds, and the default is 5 seconds.

Operation Interface

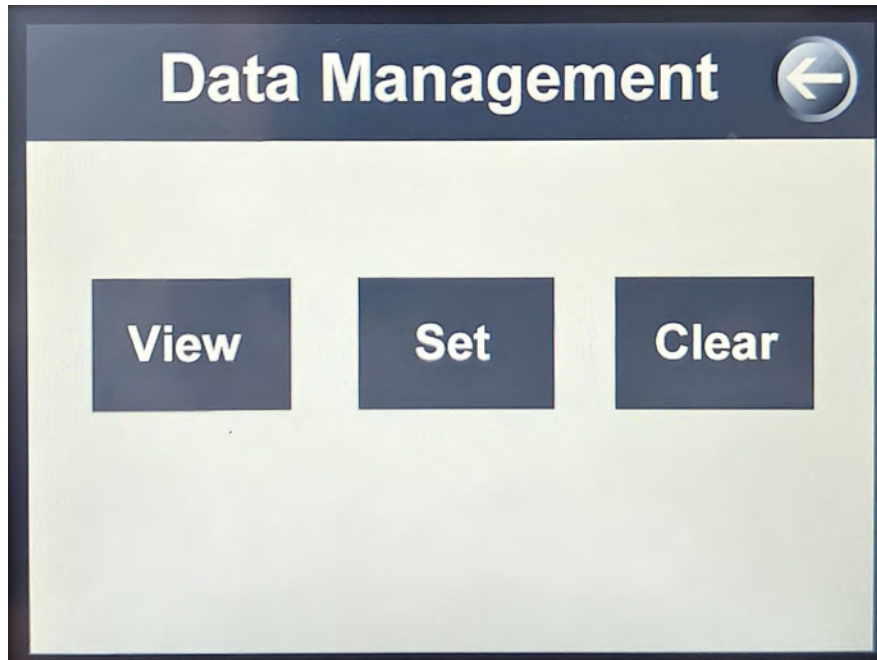

Data management: view, set, and clear data

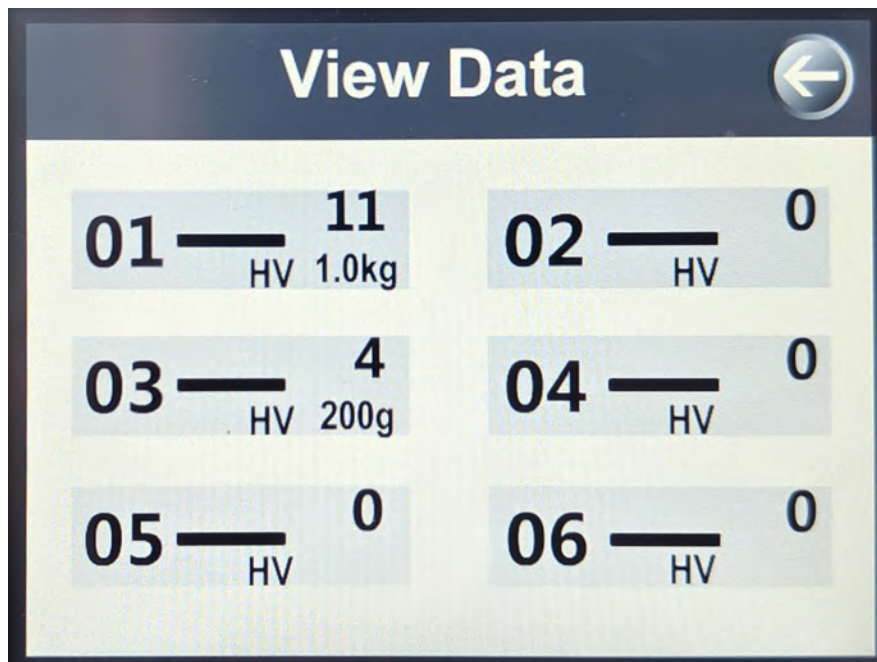

Select different folders to view data in the corresponding folder

Operation Interface



Select Folder to Save Data

SEQ#	D1	D2	HV/K
✓1	49.34	49.37	761.2
✓2	48.71	48.71	781.5
✓3	47.59	47.59	818.7
✓4	49.09	49.12	769.0
✓5	49.37	49.37	760.8
✓6	49.78	49.78	748.3
✓7	49.65	49.65	752.2
✓8	49.62	49.62	753.1
✓9	49.68	49.68	751.3
✓10	49.59	49.59	754.0

HV 1.0kg
FOLDER **1**
TOOL
MAX 818.7
MIN 748.3
AVG 766.8

View recorded test data

Operation Interface

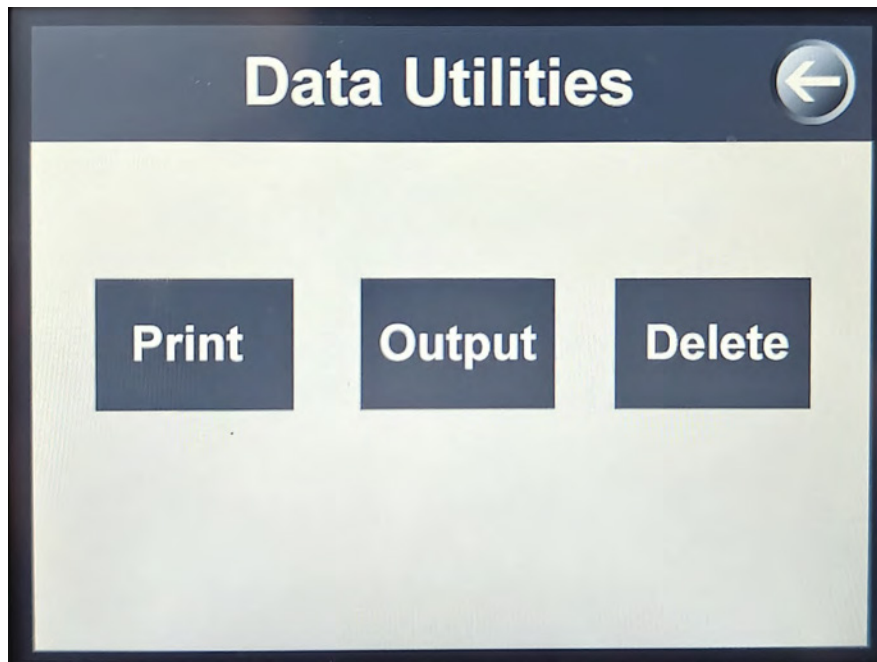

Process test data, including Print, Output, and Delete

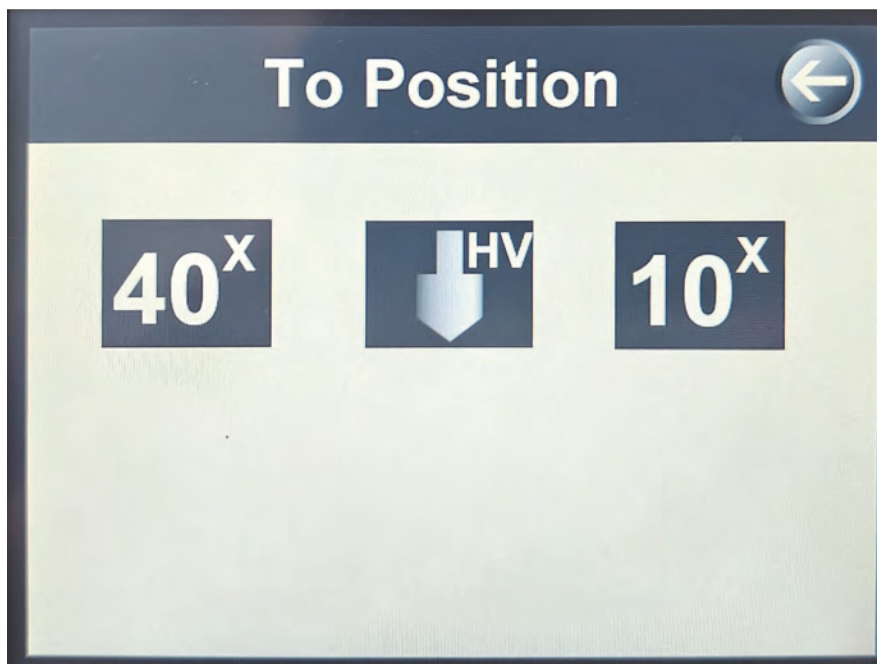

Selectable sequentially: 40x objective, indenter, 10x objective

Product Dimensions

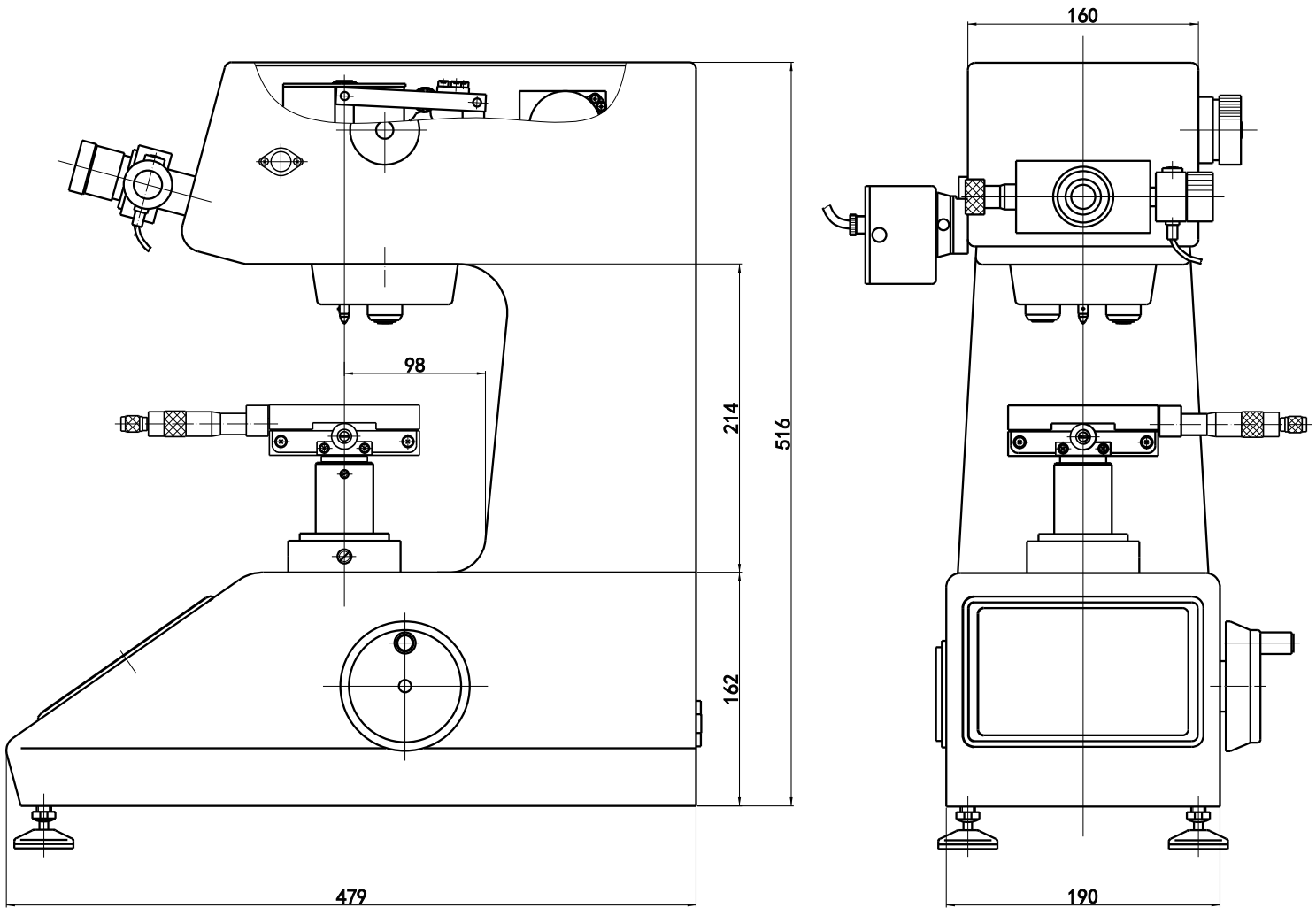









Technical Specification

Name	Touch Screen Micro Vickers Hardness Tester
Model	MVicky-1000T
Test Force	0.098N、 0.245N、 0.49N、 0.9807N、 1.961N、 2.942N、 4.903N、 9.807N 10gf、 25gf、 50gf、 100gf、 200gf、 300gf、 500gf、 1kgf
Indenter	Diamond Indenter
Test Force Application Method	Automatic application and removal of test force
Indenter And Objective Lens	Automatic switching
Test Force Dwell Time	0~60s (in 5s increments)
Eyepiece	10X
Objective Lens	10X 40X
Total Magnification	100X 400X
Resolution	0.06μm
X-Y Test Stage	Size:100x100 mm Travel:25x25mm Resolution:0.01mm
Maximum Sample Height	90mm
Indenter Center To Outer Wall	100mm Within room temperature range (23±5)°C
Working Conditions	Placed horizontally on a stable base In a vibration-free environment, free from corrosive media Indoor relative humidity not exceeding 65%
Power Supply	AC220 V/50~60 Hz
Net Weight	31KG
Dimensions (L X W X H)	480x325x545mm

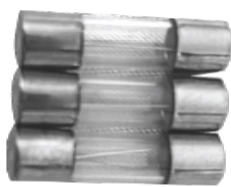
Standard Delivery

Name	Specification	Qty	Photo
Machine Mainframe		1	
Micro Indenter		1	
Objective Lens	10X、40X	each1	
Measuring Eyepiece	10X	1	
Weights		6	
Weight Shaft		1	
X-Y Test Stage		1	
Flat Clamping Stage		1	
Thin Specimen Clamping Stage		1	
Fine Wire Clamping Stage		1	

Standard Delivery

Name	Specification	Qty	Photo
Leveling Screws		4	
Spirit Level		1	
Halogen Lamp	12V、 15~20W	1	
Spare Fuse	1A/250V 5X20mm	3	
Power Cord		1	
Screwdriver		1	
Hex Key		2	
Dust Cover		1	
Microhardness Blocks	HV0.2、 HV1	each1	
Hardness Tester User Manual		1	
Certificate Qualification		1	
Product Qualification Certificate		1	
Accessories Box			

Optional Delivery

Optional Accessories

Knoop indenter

CCD image processing system

Vickers measurement software

Low-value HV1 Vickers standard hardness block (around 200)

Medium-value HV1 Vickers standard hardness block (around 500)

High-value HV1 Vickers standard hardness block (around 700)
(Standard hardness blocks for other Vickers scales are optional)
