

MIDLAND METROLOGY LTD

iVideo-0325 FA **3D Video Microscope**



Video



Features and Applications

iVideo-0325 FA 3D Video Microscope is a precise optical inspection instrument that integrates 2D/3D observation functions. It is equipped with a large-field continuous zoom lens and a 4K high-definition camera, and supports dual interfaces of HDMI and USB3.0 for output. It features core functions such as automatic focusing, multi-mode measurement, and image comparison, and is suitable for microscopic observation and precise measurement requirements in various fields such as electronic manufacturing, precision machinery, and material testing. It is easy to operate and has stable performance.

Product Features

- Equipped with a 0.6 - 5.0X continuous zoom lens, it supports one-click switching between 2D/3D observation modes. In 3D mode, it can rotate 360° for comprehensive inspection.
- Equipped with a 4K Ultra HD camera, featuring built-in fully automatic focusing function, with a maximum resolution of 3840×2160, the image is clear and detailed.
- Supports HDMI direct connection display and USB3.0 computer connection, compatible with mouse operation, integrating multiple functions such as photography, video recording, measurement, etc. into one unit.
- Offer a wide range of measurement tools, covering 18 types of measurements such as length, angle, and area.
- The measurement accuracy reaches 0.01μm, meeting the requirements of precise detection.
- Supports custom setting of grid lines, allowing for the saving of 8 preset schemes. It also features image comparison and four-screen comparison functions, facilitating multi-sample analysis.
- Equipped with four-zone light sources and a light source controller, the brightness can be adjusted. It is suitable for observing samples of different materials, reducing the interference from reflections.
- The body structure is stable. The large 330×300mm base plate ensures it stays put when placed. The operation process is visible, so it's easy for newbies to get the hang of it.

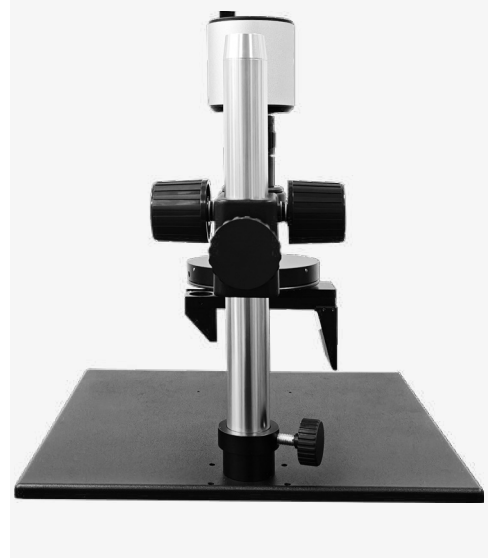

Features and Applications

Product Application

- It is applicable to the observation of microstructures and defect detection in fields such as electronic components, precision mechanical parts, PCB boards, and new materials.
- It can meet the real - time quality control requirements at the production site and the needs of precise laboratory analysis. It can be used in links such as incoming material inspection, process monitoring, and finished product acceptance.
- Supports precise measurement of product dimensions and data archiving, suitable for use in various scenarios such as research institutions, factory quality inspection, and university experiments.
- It can conduct real-time comparison and analysis between the actual images and the stored images, assisting in the consistency verification and anomaly detection during batch production.
- Suitable for samples of different materials such as metals, plastics, and electronic components, and compatible with both planar and three-dimensional structural detection requirements.

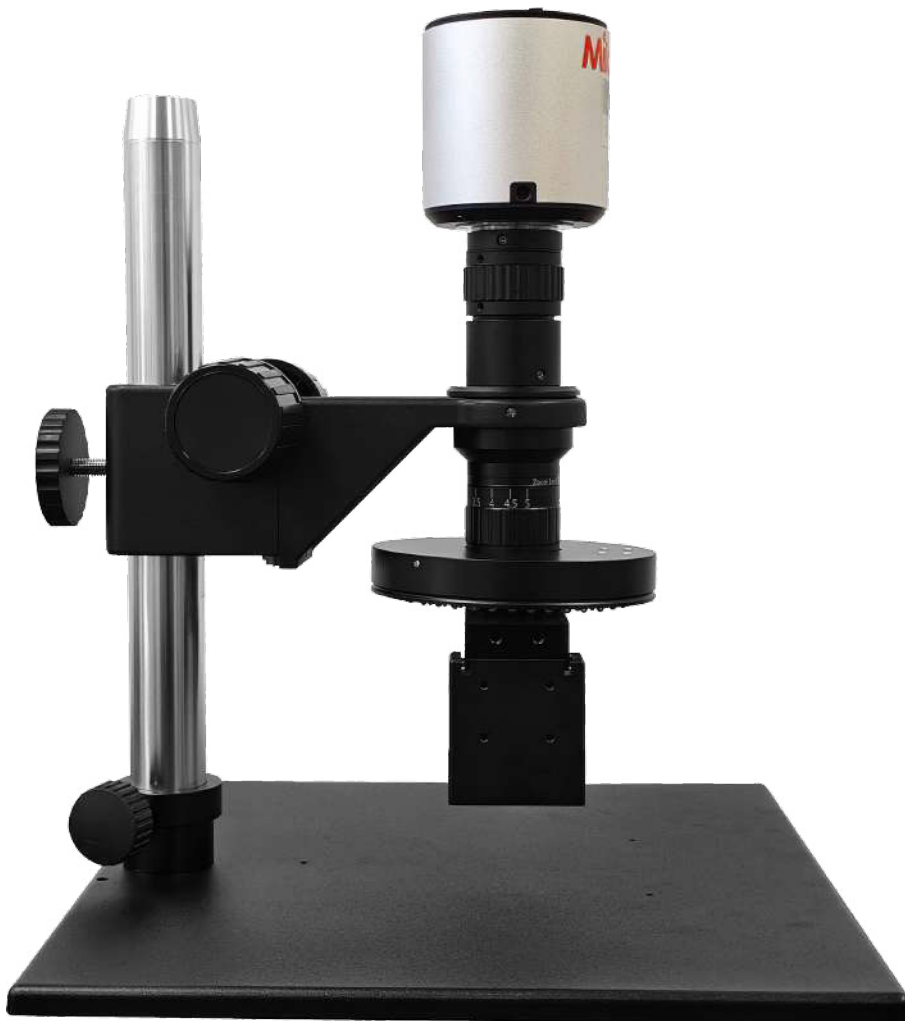

Instrument Appearance

Product Structure



1. HDMI 4K Camera

2. 0.5X CTV Connector Tube

3. 0.6 - 5.0X Continuous Zoom Eyepiece

4-zone Light Source

5. 2D/3D Viewer

330*300mm Base Plate

7. 32mm Round Column

8. Fine-tuning Focus

9. Light Source Switch Control Button

10. Light Source Intensity Control Button

11. 11.6-inch Screen

Product Details

HDMI 4K Camera

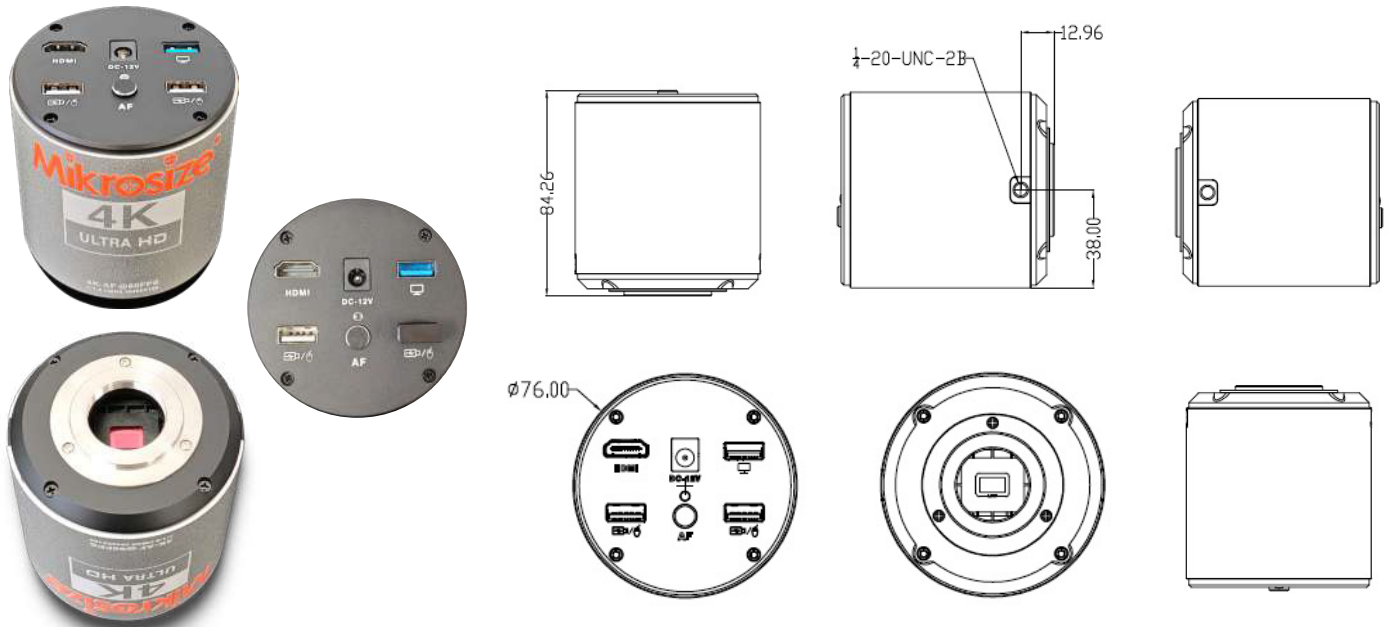

- Ultra-high-definition detail capture: With a 4K resolution and a 1/1.8-inch CMOS sensor, the pixel count is 4 times that of 1080P, enabling precise presentation of microscopic defects as small as 0.01mm, providing a reliable basis for inspection.
- Plug-and-play efficient operation: HDMI direct connection to the monitor is driver-free. Combined with mouse control, it enables quick output of real-time images upon startup. Novices can get started immediately, and it is suitable for real-time detection requirements in production lines.
- Multi-mode intelligent focusing: supports automatic, manual, and single-shot focusing. It enables precise focusing by framing an area, taking into account both rapid imaging and 3D structure detection, significantly enhancing operational efficiency.
- Dual-interface scenario adaptation: HDMI is for real-time on-site observation, while USB 3.0 is for deep analysis on a computer. It is cross-platform compatible and caters to both quality inspection and laboratory analysis requirements.
- Stable imaging in complex environments: the wide dynamic range technology balances the details of light and dark, combined with four-zone light sources, reduces reflections and noise, and is suitable for the detection of multiple material samples.
- Full-process function integration: synchronously supports 4K video recording, 18 types of measurements, image comparison, and data can be directly archived and exported, achieving the integration of "observation - analysis - recording".

Product Details

2D/3D Imaging

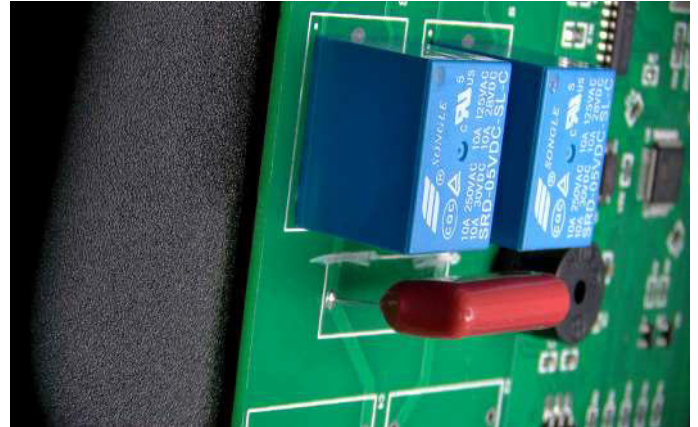
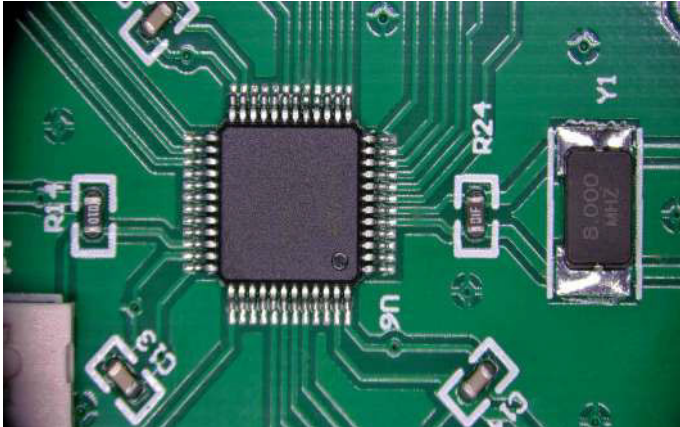

- Dual-mode precise adaptation: 2D focuses on planar measurement and surface defect detection, while 3D presents three-dimensional morphology. It can be switched by manual pushing and pulling, meeting the needs of different detection dimensions.
- 3D comprehensive observation: in 3D mode, the model can be rotated 360 degrees to re-establish the three-dimensional structure, clearly presenting details such as height differences and steps, breaking through the limitations of the traditional microscope's planar view.
- Switching zero-cost connection: when switching between 2D and 3D, the working distance and center position remain unchanged, eliminating the need for repeated focusing, ensuring a smooth and efficient detection process.
- 2D efficient and precise detection: focusing on the processing of planar information, combined with 18 measurement tools, it can quickly complete precise calculations of parameters such as size and angle, and is suitable for batch screening.
- Complex scenes with no blind spots: 3D technology can distinguish overlapping and occluded parts, 2D technology avoids interference from reflections, and the dual mode complements each other to cover the detection of multiple materials and structures.
- Wide depth-of-field clear imaging: the optical system ensures a wide depth-of-field in both modes, allowing for detailed observation at high magnification while still covering a large range of details, reducing the need for repeated focusing operations.

Product Details

Software Measurement

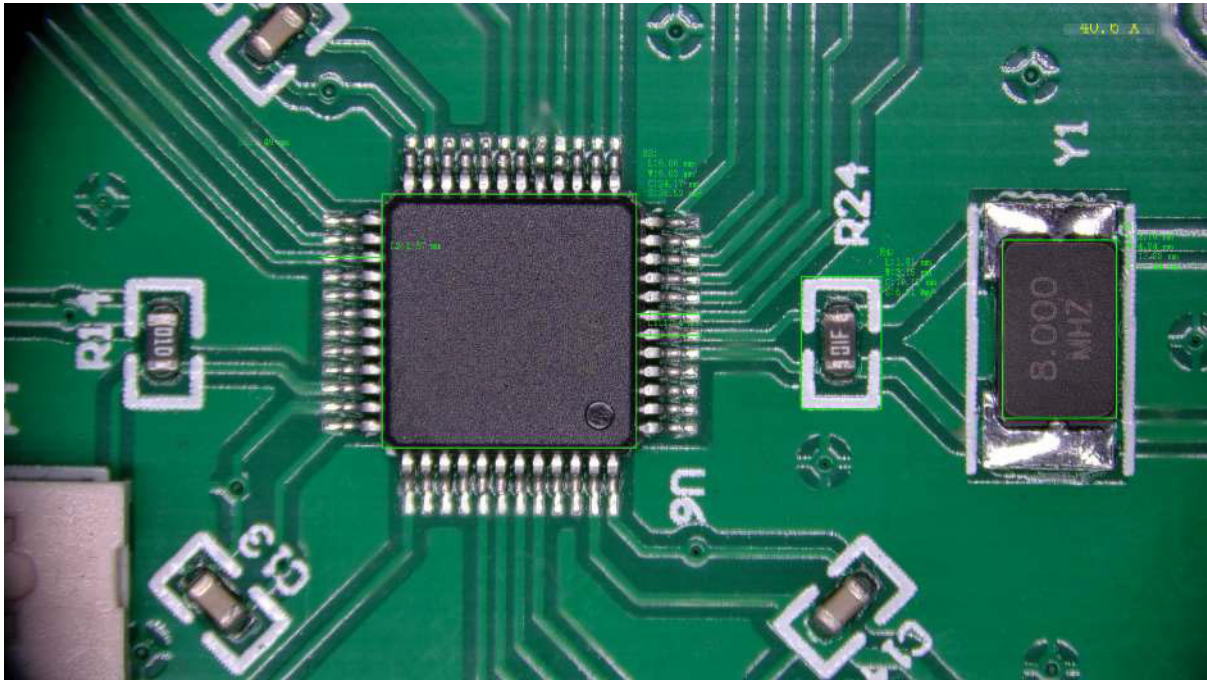

- Integrated full-process operation: Integrates observation, collection, measurement and analysis functions. No need to switch software. From real-time imaging to data archiving, it can be completed in one step, significantly simplifying the testing process.
- Intelligent auxiliary precise measurement: Supports 18 types of geometric measurements, combined with automatic edge detection technology, the measurement accuracy reaches 0.01 μ m. The results can be directly exported to Excel, ensuring data reliability.
- Intuitive and user-friendly interface design: Clear functional divisions, advanced settings hidden from beginners, supports direct mouse control, combined with a guided process, simple training enables quick operation.
- Multi-mode image optimization: Built-in HDR, shadow correction, anti-glare functions. Can adjust brightness and white balance with one click. Suitable for complex imaging environments such as reflections and low light conditions.
- Efficient data management sharing: Supports automatic naming and storage of images, can save 8 preset schemes, and data can be synchronized to the network drive, facilitating team collaboration and traceability.
- Flexible function expansion compatibility: Compatible with HDMI direct connection and computer operation, supports external storage devices, can import standard images for four-screen comparison, meeting diverse detection requirements

Product Details

Software Measurement

Ratio Setting





Objective ratio ▼





Eyepiece ▼





Monitor size inch

Show ratio 40.6 X Open







Assistance Tools







   





   





   

Measure Tool





     

Color ▼ Width ▼

Calibration

Mode     

Name ▼

Length ▼

Accuracy ▼

Ruler 0.0149 mm/ pix Open

Settings

Image **Flags** Other

Exposure Control

Auto Manual

Exposure(ms)

White Balance

Auto One Push

Red

Green

Blue

Color Temp

Image

Bright

Contrast

Saturation

Sharpness

HDR

HDR 50HZ 60HZ OFF

Mirror Flip Mono

Restore setting Apply Exit

Product Details

Software Measurement

Settings

Image Flags **Other**

Snap Setting

Name Auto Manual

Measure Setting

length perimetry width
 height short axis long axis
 radius diameter eccentricity
 slope angle area

Edge range 25 + -
Font type0 + -

Sys Setting

Language English ▼
Record 1080P 60FPS ▼
Resolution 1920x1080 ▼ Confirm
Version 5811AF-20250711-V207

Restore setting Apply Exit

Settings

Image **Flags** Other

Flags

Center Ruler

Group Group 1 ▼ Save

Object CrossLine ▼ Open

HLine 1 Lines ▼ Open

VLine 1 Lines ▼ Open

Color  ▼

Width  ▼

Restore setting Apply Exit

Instrument Dimension

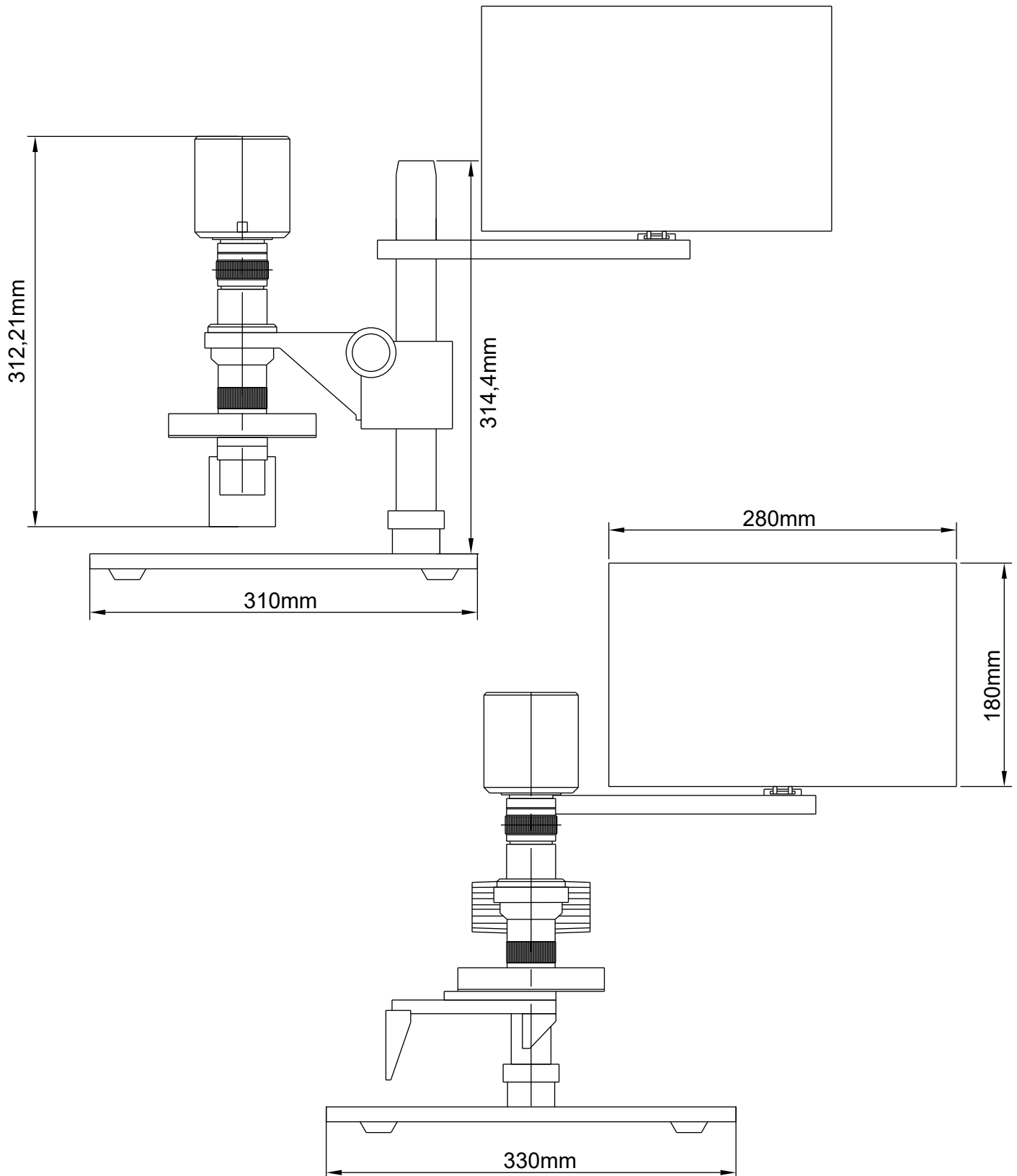





Technical Specification

Optical System	0.6 - 5.0X continuous zoom lens, 0.5X CTV adapter tube
Observation Mode	2D planar observation, 3D stereoscopic observation (360° rotation)
Camera Parameters	4K Ultra HD, 1/1.8 CMOS, resolution 3840×2160
Focus Mode	Auto focus, Manual focus, Single-shot focus
Measurement Accuracy	0.01μm
Measurement Function	18 types of measurements including length, angle, area, radius, etc.
Interface Type	HDMI, USB 3.0, USB 2.0 (for mouse), DC - 12V
Light Source System	4-zone adjustable light source, with the controller integrated onto the light source.
Show Support	Compatible with 24-inch and larger monitors, with the maximum display ratio of 456.2X.
Body Size	Base plate: 330×300mm (The height of the stand is suitable for the lens adjustment range)
Work Environment	Working temperature: 20% - 80%; Storage temperature: 0°C - 35°C
Power Supply Specifications	DC-12V power supply
Support Language	Simplified Chinese, Traditional Chinese, English

Standard Delivery

Name	Qty	Photo
Main Unit (Including Lens And Camera)	1 pc	 A black microscope-like device with a white camera lens on top, mounted on a black base.
11.6-Inch Screen	1 pc	 A black tablet-style screen displaying a green circuit board, attached to a black mounting arm.
Hdmi Cable	1 pc	 A black HDMI cable with gold-plated connectors, coiled.
USB 3.0 Data Cable	1 pc	 A black USB 3.0 data cable with a USB-A connector on one end and a micro-USB connector on the other, coiled.
DC-12V 1A Power Adapter	2 pcs	 A black DC power adapter with a two-prong AC plug and a black DC cable with a barrel jack connector.

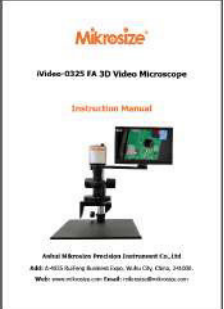
Standard Delivery

Name	Qty	Photo
DC-12V 2A Power Adapter	1pc	
Mouse	1 pc	
Operation Manual	1 pc	
Certificate of Conformity	1 pc	
Warranty card	1 pc	